

# ONKYO® SERVICE MANUAL

## COMPACT DISC PLAYER MODEL DX-G10



Black model

BUDN, BUD	120V AC, 60 Hz
BUG	220V AC, 50Hz
BUU, BUUX	110~120/220~240V AC, 50/60Hz
BUQA, BUQB	240V AC, 50 Hz

### SAFETY-RELATED COMPONENT WARNING!!

COMPONENTS IDENTIFIED BY MARK  ON THE SCHEMATIC DIAGRAM AND IN THE PARTS LIST ARE CRITICAL FOR RISK OF FIRE AND ELECTRIC SHOCK. REPLACE THESE COMPONENTS WITH ONKYO PARTS WHOSE PART NUMBERS APPEAR AS SHOWN IN THIS MANUAL.

MAKE LEAKAGE-CURRENT OR RESISTANCE MEASUREMENTS TO DETERMINE THAT EXPOSED PARTS ARE ACCEPTABLY INSULATED FROM THE SUPPLY CIRCUIT BEFORE RETURNING THE APPLIANCE TO THE CUSTOMER.

### SPECIFICATIONS

Signal readout system:	Optical non-contact
Reading rotation:	About 500~200 r.p.m. (constant linear velocity)
Linear velocity:	1.2~1.4m/s
Error correction system:	Cross interleave readsolomon code
Decoded bits:	18 bits linear
Sampling frequency:	352.8kHz (8 times oversampling)
Number of channels:	2 (stereo)
Frequency response:	2Hz~20kHz
Total harmonic distortion:	0.0015% (at 1kHz)
Dynamic range:	103dB
Signal to noise ratio:	110dB
Channel separation:	103dB (at 1kHz)
Wow and Flutter:	Below threshold of measurability
Power consumption:	24 watts
Output level:	2 volts r.m.s.
Dimensions (W x H x D):	477 x 142 x 427mm 18-3/4" x 5-9/16" x 16-13/16"
Weight:	27kg, 59.5 lbs.

Specifications are subject to change without notice.

**ONKYO**  
**AUDIO COMPONENTS**

## TABLE OF CONTENTS

Specifications . . . . .	1
Service procedures . . . . .	2
Caution on replacement of pick-up . . . . .	3
Protection of eyes from laser beam during servicing . . . . .	4
Laser warning labels . . . . .	4
Notes on compact disc . . . . .	5
Disassembling procedures . . . . .	6
Circuit descriptions . . . . .	8
IC block diagram and descriptions . . . . .	14
Adjustment procedures . . . . .	23
Mechanism exploded view . . . . .	27
Chassis exploded view . . . . .	30
Printed circuit board view . . . . .	33
Pc board parts list . . . . .	35
Schematic diagram . . . . .	40
Waveform of each section . . . . .	45
Troubleshooting guide . . . . .	47
Block diagram . . . . .	49
Packing view . . . . .	50

## SERVICE PROCEDURES

### 1. How to Release the Transport Lock

To protect the optical assembly including the laser pickup from vibration related damage during shipping, this unit is equipped with a transport lock lever located on the base.

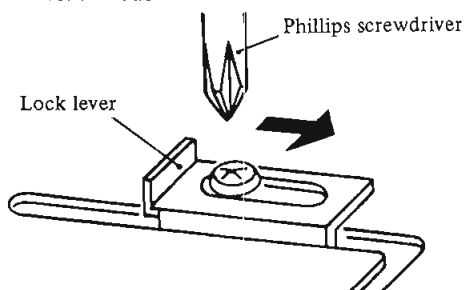

Fig. 1

- Loosen the screws with a Phillips screwdriver.
- Move the lock lever in the direction of the arrow as far as it will go.
- Tighten the screw to secure the lock lever.
  - For shipping, restore the lock lever to its position in the opposite direction from the arrow, then tighten down the screw to secure the lock lever in that position.

### 2. Procedures for replacement of flat packaged ICs

#### 1. Tools to be used:

- Soldering iron** . . . . . Grounded soldering iron or soldering iron with leak resistance of 10 Mohms or more.

Form of soldering iron's tip:

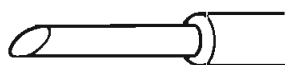

Fig. 2

- Magnifying glass** . . . . . for checking of finished works
- Tweezers** . . . . . for handling of IC and forming of leads

- Grounding ring** . . . . . Countermeasure for electrostatic breakdown
- Nipper** . . . . . for removing defective IC
- Small brush** . . . . . for application of flux
- Enamel line**

#### 2. Work Procedures:

##### (1) Remove the defective IC

Cut all leads of the defective IC one by one using a nipper and remove the IC.

- An enamel line has been pierced between the legs of the flat package IC.
- Use a soldering iron to unsolder the legs one at a time.
- Repeat the procedure of 1 and 2 above for the 3 sides only.

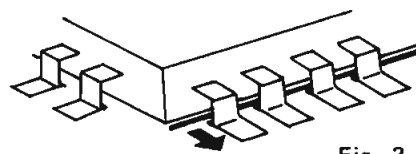

Fig. 3

While holding the soldering against the enamel line, pull in the direction of the arrow.

##### (2) Clean the pattern surface of the PC board.

Get rid of the remaining leads and solder.

##### (3) Check and form the leads of the new flat packaged IC to be installed.

From every lead on the new IC using a pair of tweezers, so that all of them are aligned neatly without being risen, twisted or inclined toward one side. Especially the rising portion of every lead must be formed with greatest care.

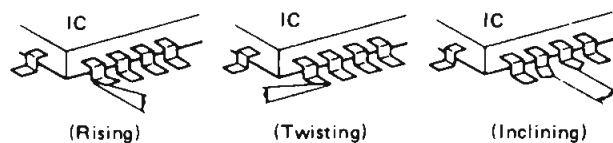

Fig. 4

##### (4) Apply flux to the PC board.

Apply flux to the pattern surface of the PC board which has been cleaned, as shown in the illustration. The area to be applied with flux is the portion of about 2.5mm in width where the IC's leads are to be soldered.

Be careful to apply minimum amount of flux required so as not to smear it on unwanted areas.

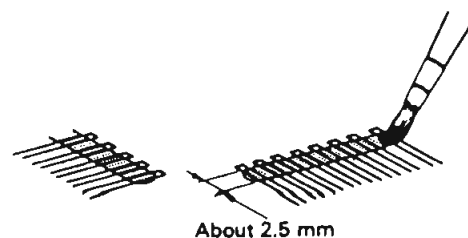

Fig. 5

**(5) Temporarily tighten the IC**

Carefully align the pattern and IC's leads, so that the IC will be temporarily tightened to the pattern on the four leads at the corners. At this time, soldering is required, but no need to apply soldering material.

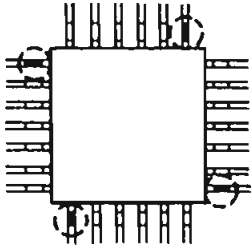

Fig. 6

**(6) Apply flux to IC's leads**

Apply flux to the areas of IC's leads where soldering is to be performed. Be careful not to smear flux on the root portion of any lead or the body of IC.

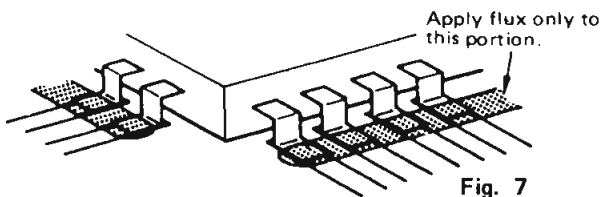

Fig. 7

**3. Voltage Selector (Rear Panel)**

Worldwide models are equipped with a voltage selector to conform with local power supplies. Be sure to set this switch to match the voltage of the power supply in your area before turning the power switch on. Voltage is changed by sliding the groove in the switch with a screwdriver to the right or left. Confirm that the switch has been moved all the way to the right or left before turning the power switch on. Models without a voltage selector can only be used in areas where the power supply is the same as that of the unit.

**CAUTION ON REPLACEMENT OF PICK-UP**

The laser diode in the optical pick-up block is so sensitive to static electricity, surge current and etc. that the components are liable to be broken down or its reliability remarkably deteriorated.

**PRECAUTIONS****1. Ground for the work-desk.**

Place a conductive sheet such as a sheet of copper (with impedance lower than  $10^6 \Omega$ ) on the work-desk and place the set on the conductive sheet so that the chassis.

**2. Grounding for the test equipment and tools.**

Test equipments and toolings should be grounded in order that their ground level is the same the ground of the power source.

**(7) Soldering**

While attaching the tip of the soldering iron to the soldering point as shown in the illustration, feed 2–5mm of soldering wire. Then, slowly move the iron in the direction indicated by the arrow in the illustration, so that the leads will be soldered to the pattern. Move the iron in the rate of approximately 1cm in 5sec. Proceed with your work while confirming a clean fillet of solder is formed on each lead, subsequent to the melting of flux.

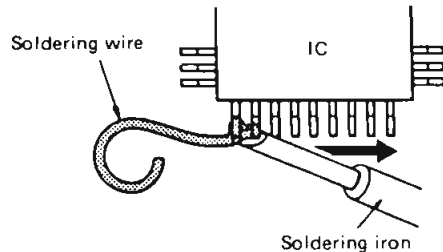

Fig. 8

**CAUTION**

- 1) If you move the iron too quickly, loose soldering is likely to result.
- 2) Be especially careful when soldering the first lead where loose soldering is most liable to be formed.

**(8) Check the results**

When soldering of all leads is finished, check the soldered portion on every lead with a magnifying glass. A tester must not be used or checking of any soldered position

**4. Safety-check out**

After correcting the original service problem, perform the following safety check before releasing the set to the customer:

Connect the insulating-resistance tester between the plug of power supply cable and chassis.

Specifications: more than 10Mohm at 500V.

During repair, carefully take the following precautions. (The following precautions are included in the service parts).

**3. Grounding for the human body.**

Be sure to put on a wrist-strap for grounding whose other end is grounded.

Be particularly careful when the workers wear synthetic fiber clothes, or air is dry.

**4. Select a soldering iron that permits no leakage and have the tip of the iron well-grounded.****5. Do not check the laser diode terminals with the probe of a circuit tester or oscilloscope.**

## PROTECTION OF EYES FROM LASER BEAM DURING SERVICING

This set employs a laser. Therefore, be sure to follow carefully the instructions below when servicing.

### WARNING!!

WHEN SERVICING, DO NOT APPROACH THE LASER EXIT WITH THE EYE TOO CLOSELY. IN CASE IT IS NECESSARY TO CONFIRM LASER BEAM EMISSION, BE SURE TO OBSERVE FROM A DISTANCE OF MORE THAN 30cm FROM THE SURFACE OF THE OBJECTIVE LENS ON THE OPTICAL PICK-UP BLOCK.

## LASER WARNING LABEL

The label shown below are affixed.

### 1. Warning label

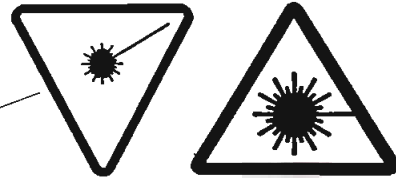
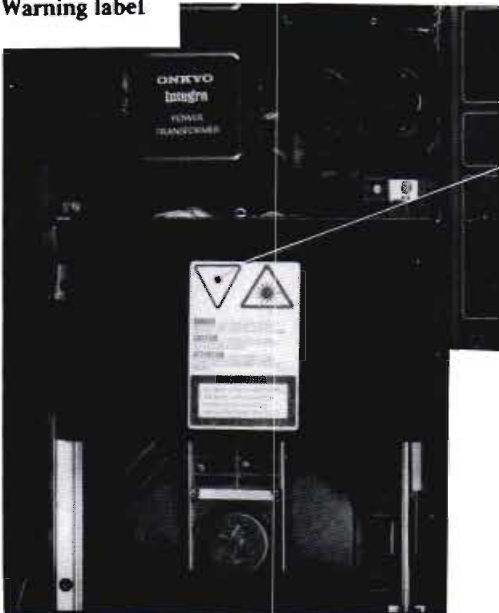

**DANGER** —INVISIBLE LASER RADIATION WHEN OPEN AND INTERLOCK FAILED OR DEFEATED. AVOID DIRECT EXPOSURE TO BEAM.

**CAUTION** —HAZARDOUS LASER AND ELECTROMAGNETIC RADIATION WHEN OPEN AND INTERLOCK DEFEATED.

**ATTENTION** —RAYONNEMENT LASER ET ELECTROMAGNETIQUE DANGEREUX SI OUVERT AVEC L'ECLANCHEMENT DE SECURITE ANNULE. SN29360911

ADVARSEL: USYNLIG LASERSTRÅLING VED ÅBNING, NÅR SIKKERHEDSAFBRYDER ER UDE AF FUNKTION. UNDGÅ UDSÆTTELSE FOR STRÅLING.

### 2. Certification label (UD: 120V model)

This label is located on the back panel.

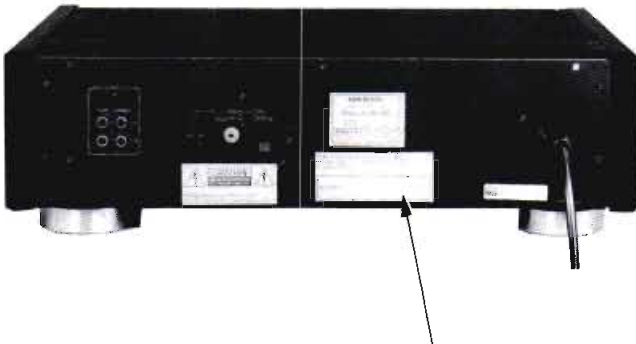

### 3. Class 1 label (Other models)

This label is located on the back panel.



## ADVARSEL

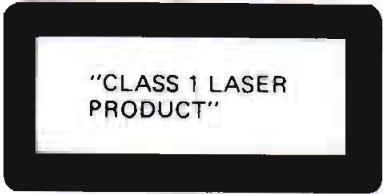

"CLASS 1 LASER  
PRODUCT"

Denne mærkning er anbragt på apparatets højre side og indikerer, at apparatet arbejder med laserstråler af klasse 1, hvilket betyder, at der anvendes laserstråler af svageste klasse, og at man ikke på apparatets yderside kan blive udsat for utilladelig kraftig stråling.

APPARATET BØR KUN ÅBNES AF FAGFOLK MED SÆRLIGT KENDSKAB TIL APPARATER MED LASERSTRÅLER!

Indvendigt i apparatet er anbragt den her gengivne advarselmærkning, som advarer imod at foretage sådanne indgreb i apparatet, at man kan komme til at udsætte sig for laserstråling.



ADVARSEL USYNLIG LASERSTRÅLING  
VED ÅBNING. NÅR SIKKERHEDSAF  
BRYDER ER UDE AF FUNKTION  
UNDGÅ UDSÆTTELSE FOR STRÅLING

VAROITUS! Laite sisältää laserdiodin, joka lähettää (näkymättömiä) silmille vaarallista lasersäteilyä.

## NOTE ON COMPACT DISC

- **Holding Compact Discs**

Hold Compact Discs by the edges so that you do not touch the surface of disc. Remember that the side of the disc with the "rainbow" reflection is the side containing the audio information.

Do not attach tape or paper to the label side of the disc and always be careful not to leave fingerprints on the side that is played.

- **Storing Compact Discs**

Store Compact Discs in a location protected from direct sunlight, high heat and humidity and extremely high and low temperatures. Discs should never be left in the trunk or interior of an automobile in the sun since the temperature can become very high in such a closed environment.

Always store Compact Discs in the holders in which they were sold. Never leave a disc in the player's disc holder for a long period of time.

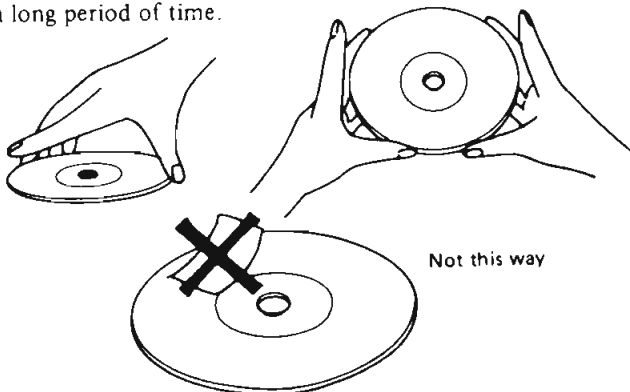

- **Cleaning Compact Discs**

Before playing a disc wipe off the playing surface with a soft cloth to remove dust and other soil. Wipe the surface in straight lines from the center of the disc outward, not in a circular motion as you would with a phonograph record.

Do not use benzene, chemical cleansers or phonograph record cleaning solutions to clean Compact Discs. Also avoid static electricity prevention solutions since they can damage the surface of Compact Discs.

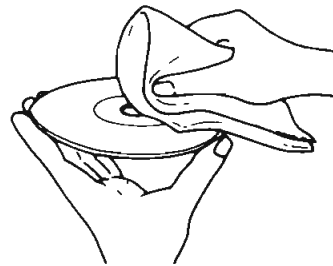

- **Problems Caused by Dew**

Dew can form inside a Compact player when it is brought from a cold environment into a warm room, when a room is rapidly heated and if a player is left in a humid environment.

This dew can prevent the laser pickup from reading the data contained in the pits in the disc surface. If the player does not operate properly because of dew, remove the disc and leave the player's power switch on for about one hour to remove all moisture.

## DISASSEMBLING PROCEDURES

### 1. Top panel removal

- Remove the four screws holding the side panels and side brackets.
- Remove the four screws holding the top panel F (A302:Front side) and side brackets.
- Remove the three screws holding the top panel B (A301:Back side) and back panel.

### 2. Analog circuit pc board ass'y removal (NAAF-3166-3)

- Remove the top covers F and B.
- Remove the four screws holding holder lid (A012) and Analog pcb ass'y.
- Disconnect the five fiber cables on the Analog pcb ass'y.
- Remove the two screws holding back panel and shielded plate (A008) on the Output terminal pcb ass'y. (NAAF-3167-2)
- Remove the shielded plate (A026) on the mechanism CD. (Two screws)
- Disconnect the three sockets (JL212, JL502 and P542) on the Analog pcb ass'y.
- Remove the bracket PC (A011). (Two screws)
- Remove the bracket B (A014). (Two screws)
- Remove the analog circuit pcb ass'y.
- CAUTION:Put the analog pcb on the insulated sheet.

### 3. Digital circuit pc board ass'y removal

- Remove the analog circuit pcb ass'y.
- Remove the shielded plate (A015). (Two screws)
- Remove the digital circuit pc board ass'y. (Four screws)

### 4. Stringing diagram of loading section

- Thread the stringing from 1 to 5.

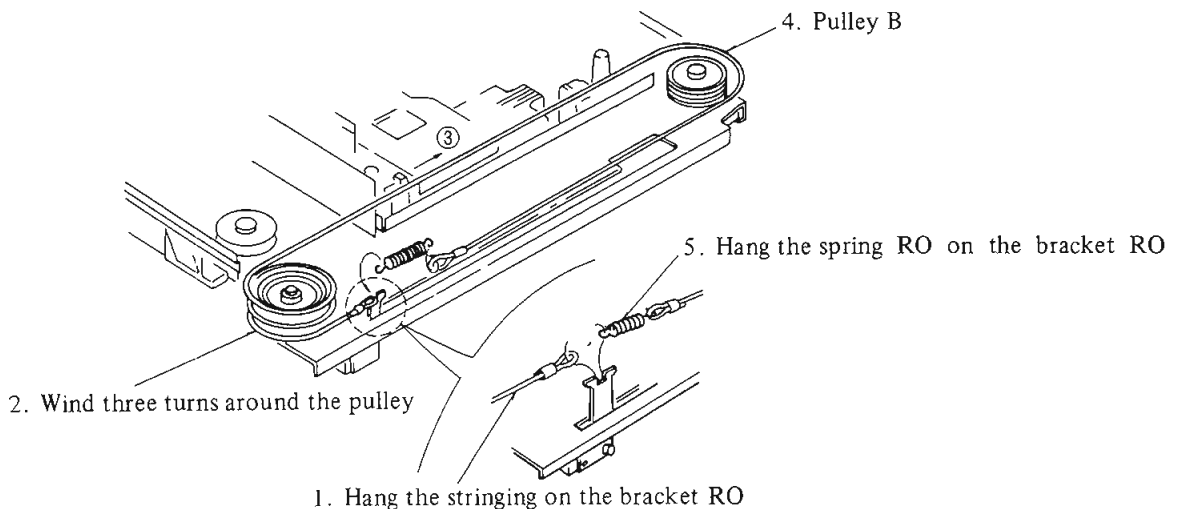

### 5. Disc pulley removal

- With the disc table in the closed position and no disc loaded, manually lift the chucking arm.
- Remove the disc pulley by inserting a screwdriver under the small tab.

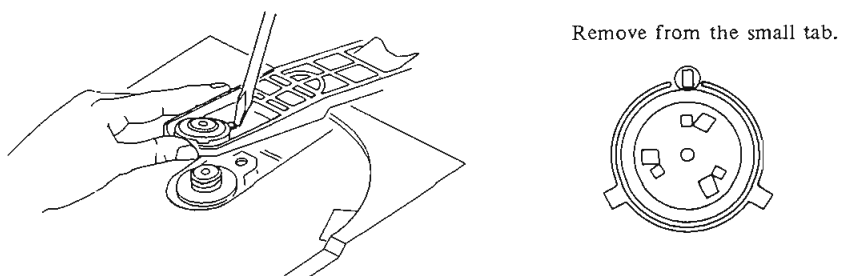

## 6. CD drive unit removal

After removing the loading section of the mechanism the CD drive unit can be removed by unscrewing the three screws which float the chassis assembly.

**Note 1:** Take care not to expose the unit to static electricity when changing the chassis assembly. (See cautions regarding handling of the laser pickup.)

**Note 2:** The tensions of the three spring on which the assembly rests are different, so take care not to mix them up.

**Note 3:** The drive unit (BU-1) is treated as a single assembly. Consequently, parts such as the RF circuit board cannot be replaced singly.

Spring	Colour
B	Black
S	White
G	Silver

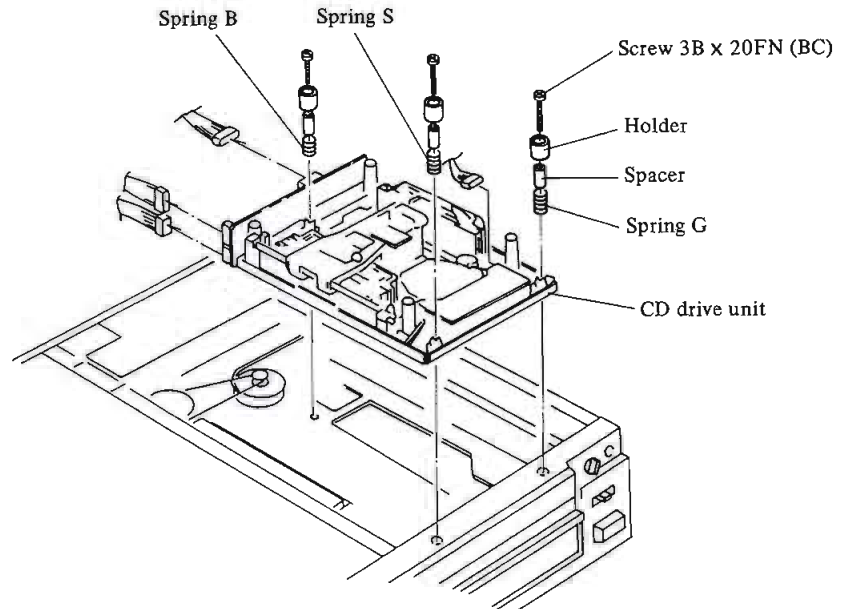

## 7. Chucking arm height

With a disc loaded and the disc tray closed, adjust the height of the portion marked "A" in the figure below to 1mm. After adjusting, perform the loading operation a few times to confirm that the arm and the cap do not touch.

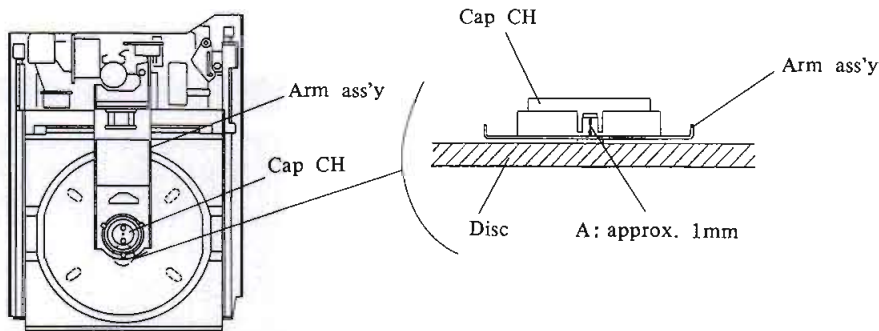

## CIRCUIT DESCRIPTIONS

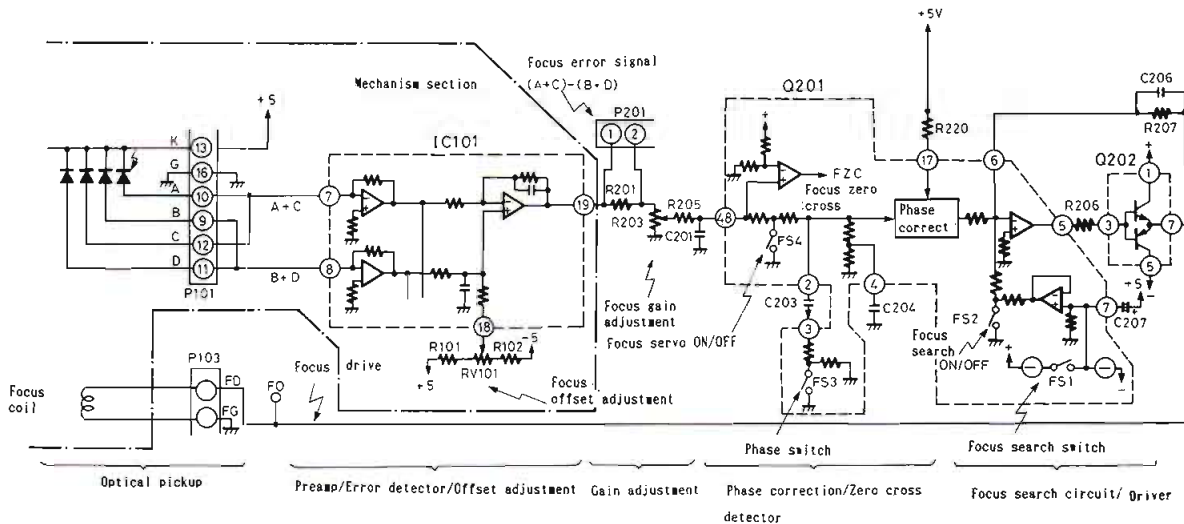

Fig. 1 Focus servo circuit

### 1. Focus servo circuit

From the optical pickup objective lens, the emitted laser beam is focused on the disc reflecting surface, and this circuit controls the movement of the lens up and down.

#### 1-1. Error detecting circuit

The error is detected by means of the astigmatic aberration method and obtains its focus error signal from the optical pickup output signal  $(A+C)-(B+D)$ .

The individual signals  $(A+C)$  and  $(B+D)$  input to pins 7 and 8 of IC101 are subtracted by means of the IC internal op amp, and from pin 19, the F.E. signal is output. Also, in order to eliminate the focus error, offset adjustment is carried out by the semi-fixed resistor RV101 of pin 18 of IC101.

#### 1-2. Phase correction and driver circuit

By means of the semi-fixed resistor R203, the gain adjusted F.E. signal passes by way of the phase correction circuit from pin 48 of Q201, and from pin 5 of Q201 to the driver Q202, and is feedback to the coil used for driving the optical pickup objective lens. In addition, there are the FS 4 servo ON/OFF switch and FS3 phase characteristic selector switch.

#### 1-3. Focus zero cross circuit and focus search circuit

In order to have mandatory drive of the objective lens in the capture range of only  $10\mu\text{m}$  at the focus point it is necessary to turn off the above mentioned FS4 and close the servo loop. The timing diagram for that operation is shown in Fig. 2.

The triangular wave generated by means of the focus search circuit internal to Q201 shifts the objective lens up/down direction, and at the correct focus point, the fall of F.E. signal is detected by the focus zero cross (FZC) circuit to close the servo loop. At this time, it is necessary that the focus OK (FOK) signal be in the high level. In Fig. 2, the dotted line is the waveform of the focus capture failure.

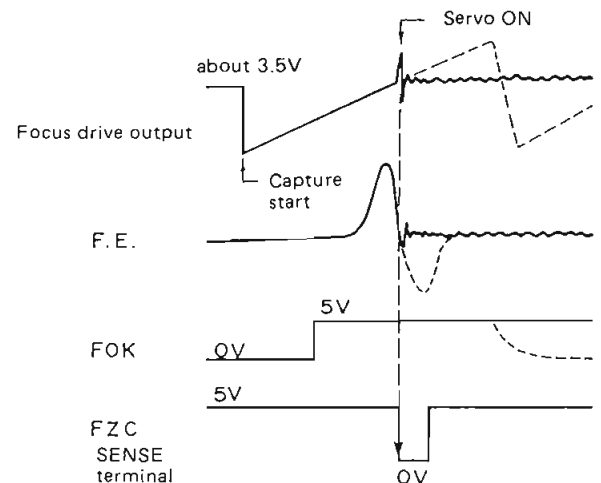
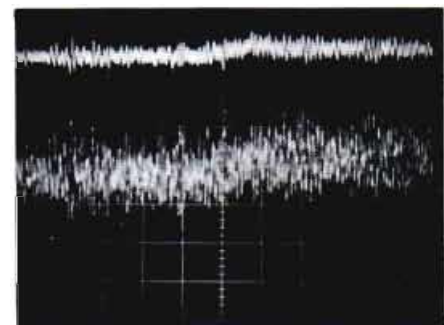

Fig. 2 Capture operation of focus



Focus signal  
Upper P201  
Lower F0(TP)  
Vertical:0.2V/div.  
Horizontal:5ms/div.



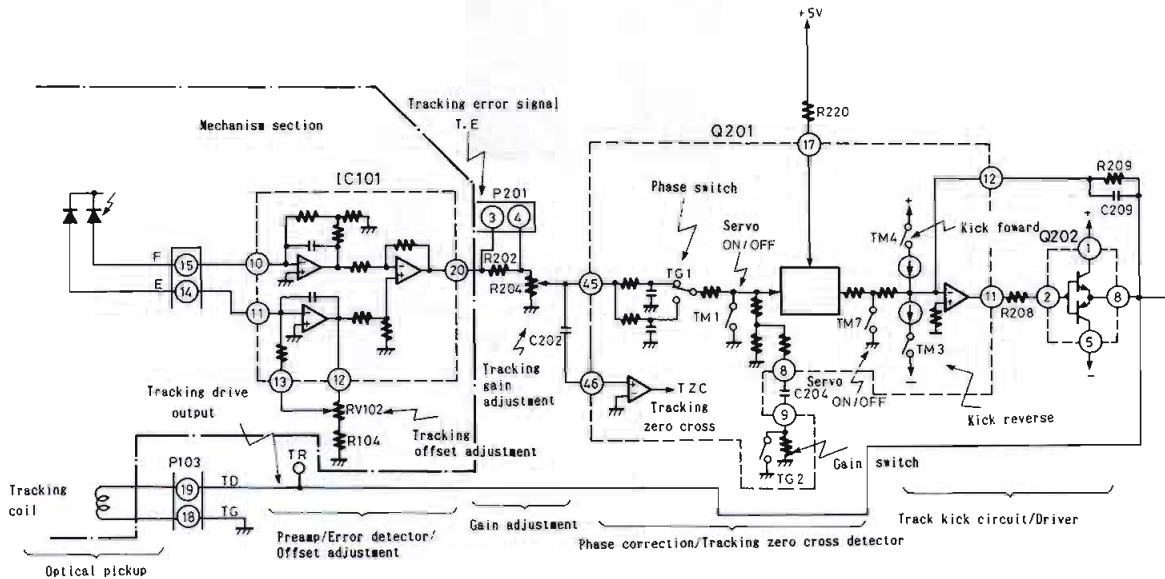

Fig. 3 Tracking servo circuit

## 2. Tracking servo circuit

On the disc at a pitch of  $1.6\mu\text{m}$ , the laser beam accurately traces the center of the pits cut into the disc, and this is the control circuit that shifts the objective lens in the radial direction.

### 2-1. Error detection circuit

The F-E is obtained from the tracking error (T.E.) signal by means of a 3 beam method. The F.E. signal input to pins 10 and 11 of IC101 is subtracted internally, and is output as the T.E. signal from pin 20. RV102 is the semi-fixed resistor control for tracking offset.

### 2-2. Phase correction and driver circuit

The T.E. signal adjusted for gain by means of the semi-fixed resistor R204 passes through the phase correction circuit from pin 45 of Q201, and from pin 11 by way of driver Q201 objective lens. TM1 and TM7 are used as the tracking servo ON/OFF switches, and TG1 and TG2 respectively are used as the phase selector and gain selector switches.

### 2-3. Tracking zero cross and track kick circuit

At the time the head comes out and when there is manual fast forward, in the event that it is necessary to skip over the track being traced, the T.E. signal receives a kick pulse, and by means of this, shifting of the objective lens can be achieved.

TM3 and TM4 respectively are the switches for providing the forward and reverse direction kick pulses. Also, the tracking zero cross (T.Z.C.) circuit counts the number of tracks skipped over and produces the signal in order to determine the timing of the servo ON/OFF.

The ON/OFF command for these switches is output from the microprocessor.

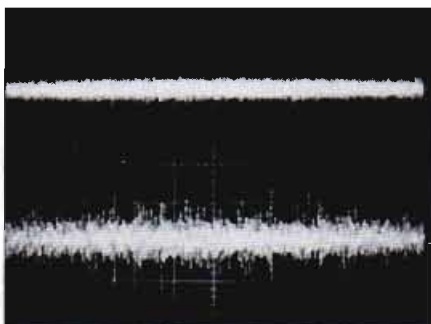

Tracking signal  
Upper P201  
Lower tr (TP)  
Vertical: 1V/div.  
Horizontal: 5ms/div.

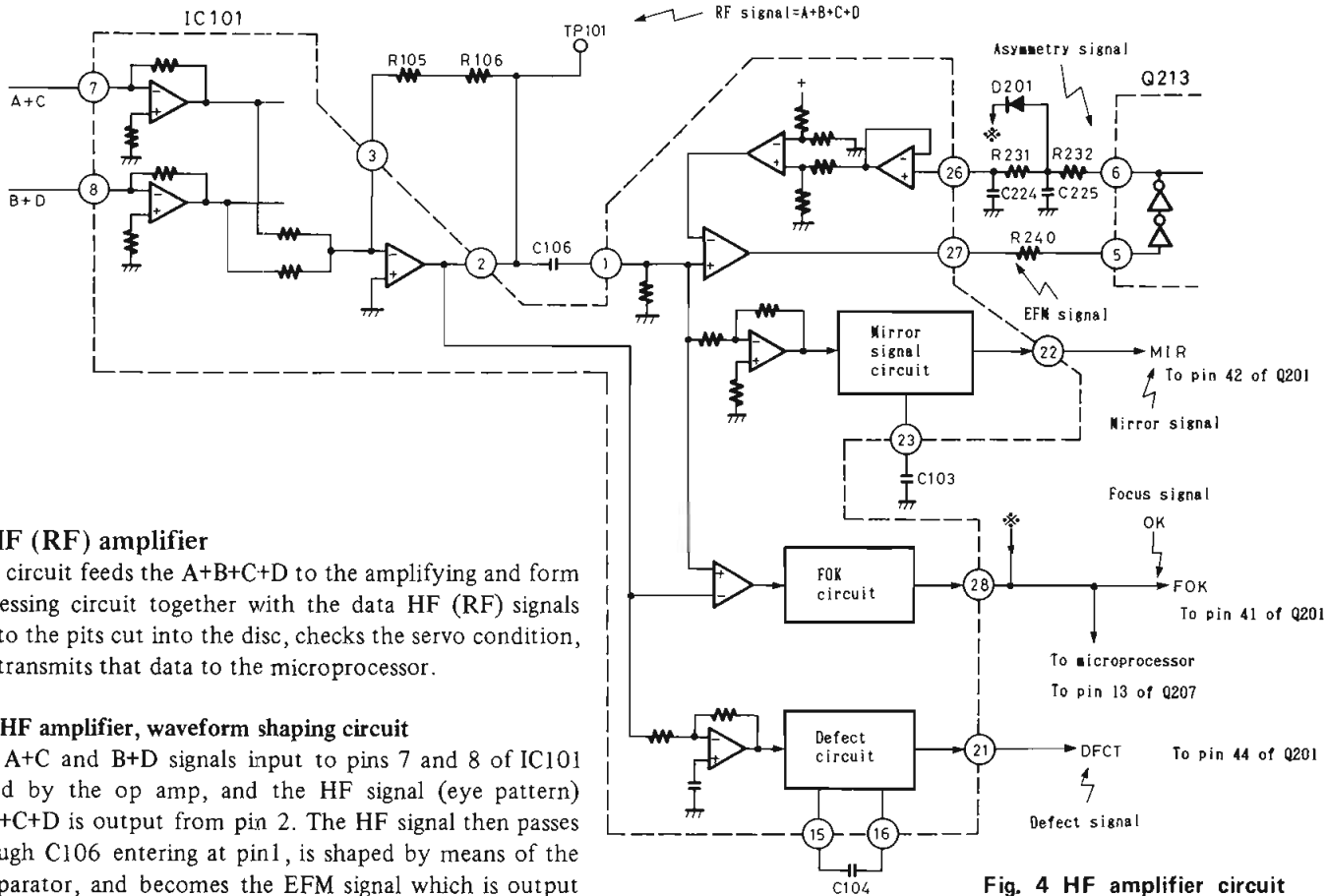

Fig. 4 HF amplifier circuit

**3. HF (RF) amplifier**

This circuit feeds the A+B+C+D to the amplifying and form processing circuit together with the data HF (RF) signals due to the pits cut into the disc, checks the servo condition, and transmits that data to the microprocessor.

**3-1. HF amplifier, waveform shaping circuit**

The A+C and B+D signals input to pins 7 and 8 of IC101 added by the op amp, and the HF signal (eye pattern) A+B+C+D is output from pin 2. The HF signal then passes through C106 entering at pin1, is shaped by means of the comparator, and becomes the EFM signal which is output from pin 27.

In the comparator threshold value, the EFM signal low region component ASY (asymmetry) is input from pin 26, and control is achieved by this means.

**3-2. MIR circuit, FOK circuit, and DFCT circuit**

After the HF signal is processed the detection, shaping, etc, respectively the MIR, FOK, and DFCT signals are output from pins 22, 28, and 21.

**3-2-1. MIR (mirror) signal**

When the head is extended, at the time the signal becomes high at the disc track and between tracks, the number of tracks is counted, and this is used for determining the timing for the ON/OFF of the servo.

**3-2-2. FOK (focus OK) signal**

This signal goes high at the time the focus servo is required. (Refer to 1-3)

**3-2-3. DFCT (defect) signal**

If there is a defect (scratch, dirt, etc.) in the disc, this signal goes high, the servo and gain are controlled, and the circuit prevents a sound outburst.

**4. CLV servo circuit**

In the compact disc there is a CLV system (constant linear velocity), and at the replay position, because the disc rotary speed varies, the clock is taken out of the HF signal, and the PLL circuit and its clock must be synchronized to control the spindle motor.

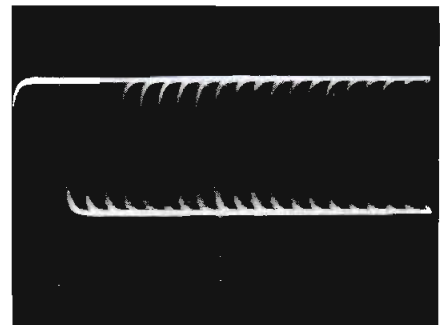

EFM output signal  
Vertical: 1V/div.  
Horizontal: 5ms/div.  
Insert the resistor 2.2kohm between probe of oscilloscope and test point.

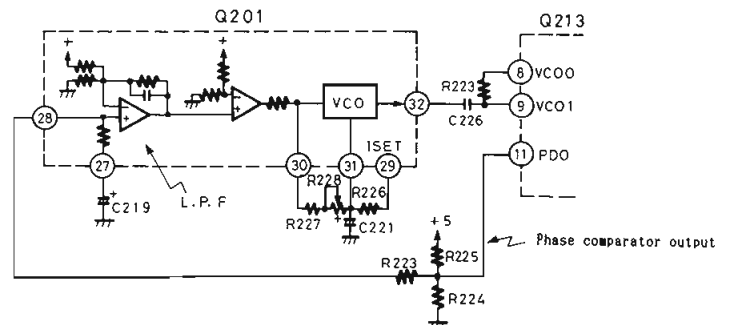

Fig. 5 PLL circuit

#### 4-1. PLL circuit

As shown in Fig. 5, for the phase comparator, in Q213 the LPF and VCO are each built into Q201. The semi-fixed resistor R228 is the control for adjusting the 4.3225 MHz free run frequency (WFCK = 7.35 KHz).

#### 4-2. Spindle motor control circuit

The output of the phase comparator (MDP) and frequency comparator (MDS) from pins 3 and 4 of Q213 is fed to pins 34 and 36 of Q201. Also, the spindle motor ON/OFF signal (MON) from pin 2 of Q213, and the phase selector signal (FSW) from pin 1, are output and fed to pin 36 of Q201. After these signals are processed in Q201, they are passed from pin 39 through the driver IC151, and are supplied to the spindle motor.

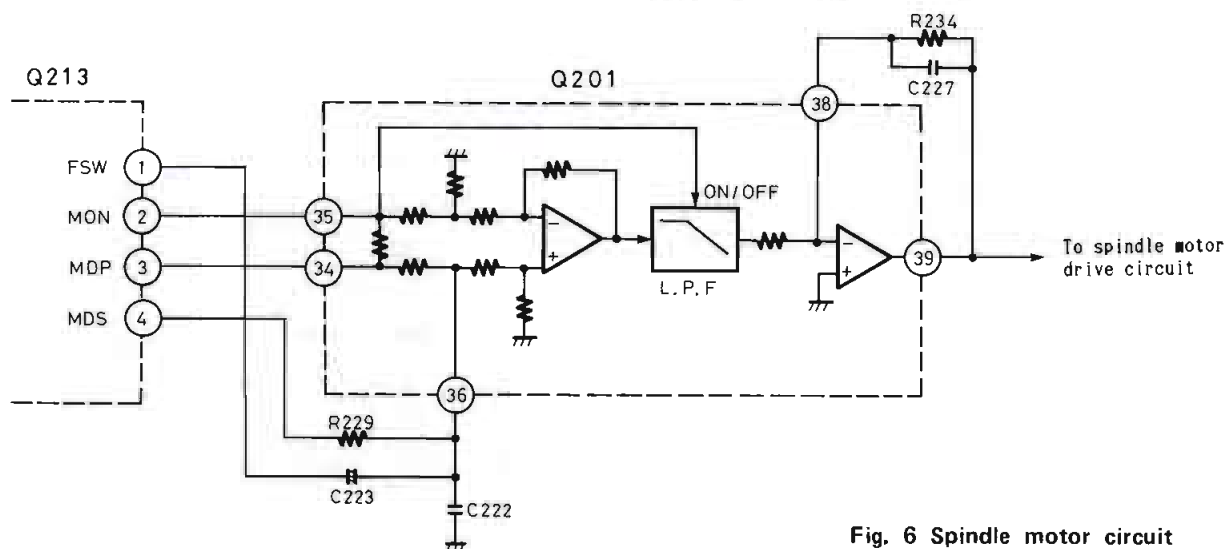

Fig. 6 Spindle motor circuit

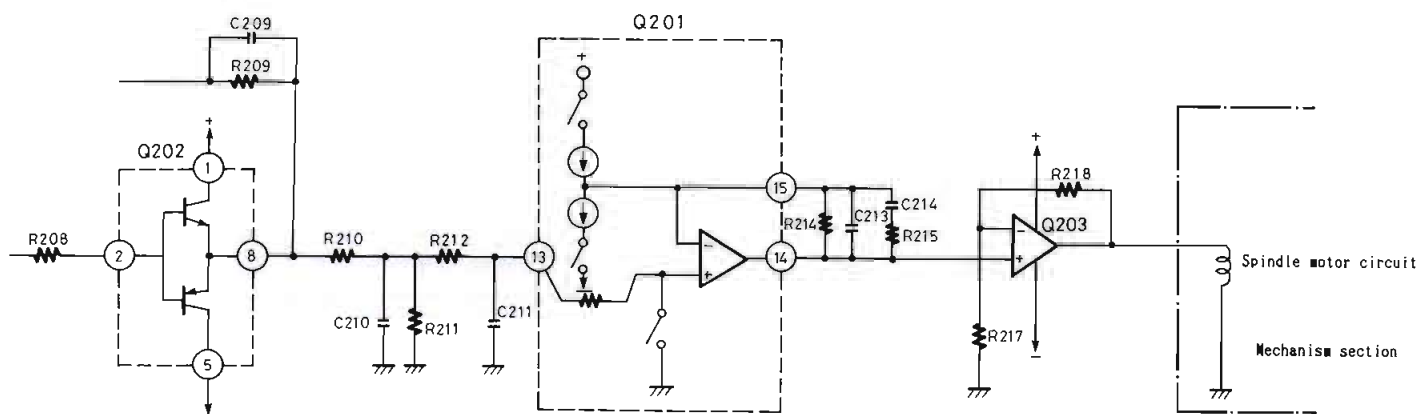
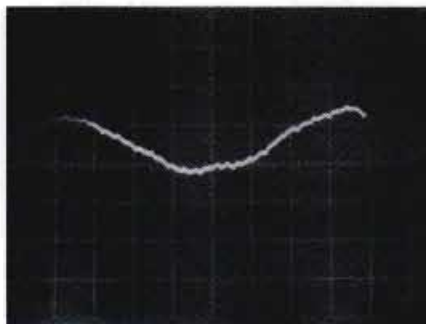

Fig. 7 slide motor circuit

#### 5. Slide motor circuit

This circuit controls the slide motor which is used for moving the optical pickup from inside the disc to the outside. In the normal playback time, the low region component of the tracking driver output is amplified and fed to the motor, but when the head is extended, switches TM5 and TM6 internal to Q201 control the ON/OFF.



SLD signal (T.P)  
Vertical: 1V/div.  
Horizontal: 20ms/div.

**6. Digital filter and interface**

The digital signal processor output signal (Q213) and the control signals are input into a digital filter (Q302). Here they undergo 8-times oversampling and are output at an 8-times higher rate. These signals pass through the interface circuitry (Q303 – Q305) where they are converted into signals to drive the 18-bit DAC unit.

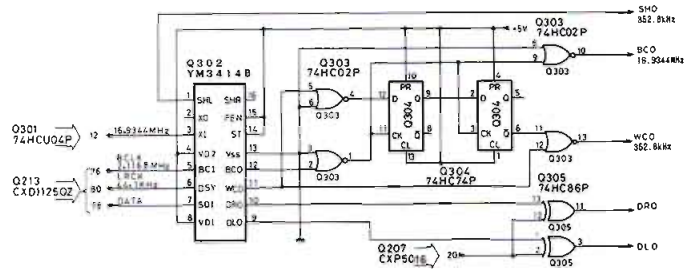

**Fig. 8 Digital filter and interface circuit**

**7. Optical data transfer transmitter drive**

The circuitry illustrated in Fig. 9 superimposes the WCO signal on the emphasis signal and drives the optical circuitry. WCO is a repeating 352.8kHz signal. EMPHA is a “high” or “low” DC signal. When EMPHA is high (emphasis on), Q309 is conductive and the bias of Q308 is determined by division of R314 and R313. On the other hand, if EMPHA is low (emphasis off), Q309 is non-conductive, so the bias of Q308 is determined by division of R313, R312 and R314. The WCO signal is blocked by C310 and R313 in order to prevent it from changing the bias. The voltage changes which occur during emphasis operation are illustrated in Table 1.

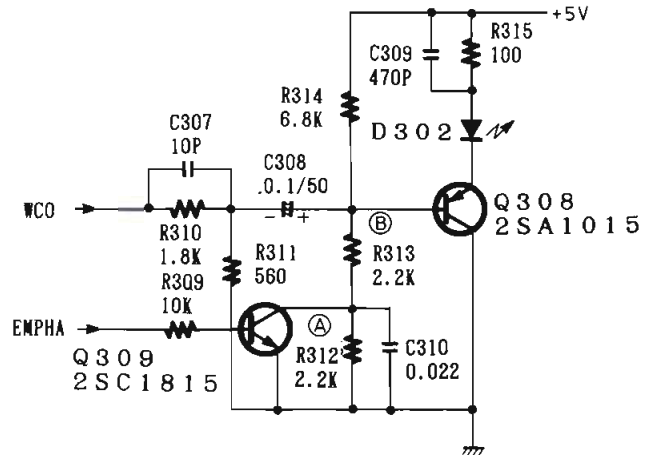

**Fig. 9 Opto. transfer circuit drive circuit**

Operation \ Voltage (V)	Voltage (V)		
	A	B	C
Emphasis ON	0	1.3	3.7
Emphasis OFF	1.0	2	4.3

**Table 1**

**8. Optical data transfer receiver preamplifier**

The superimposed WCO and EMPHA signals are transmitted via an optical fiber cable and received by D402 where they are converted into an electrical signal. The WCO signal is input into Q402 pin 1. R414 is the load resistance. After being amplified by Q402, it is output from pin 5. Next, after passing through waveform shaping circuit Q407, it is used as the D/A converter word clock signal. The optimum operation point varies due to inconsistencies in the sensitivity of the optical transmitter and receiver outputs (D302 and D402). Therefore, semi-fixed resistor R411 is provided for adjustment.

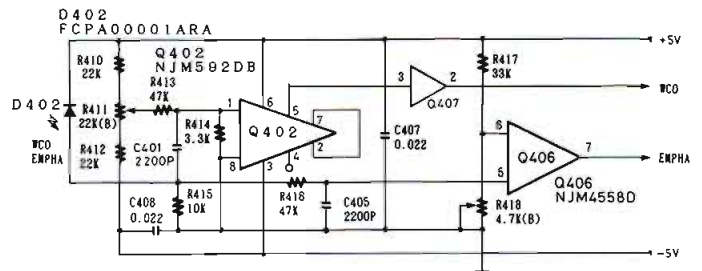

**Fig. 10 Optical data transfer receiver preamplifier circuitry**

The WCO signal is removed from the EMPHA signal by a filter consisting of C405 and R416. Only the DC signal elements are input into Q406 pin 5. R415 is the load resistance. The emphasis on and off center voltages are set with semi-fixed resistor R418.

**9. Serial-parallel interface**

The data signal, after demodulation in the optical receiver preamplifier, is converted into a parallel signal in the interface circuitry illustrated in Fig. 11.

The converted signal is then input into the parallel-input 18-bit D/A converter.

The 18 data bits (DAL) are assigned to the registers (Q409, Q411 and Q413) using the 18-bit bit clock signal. The 19th bit of the bit clock signal activates the word clock (WCO) and the values of each of the registers are output. This output is held until the next 18 bits of data are collected.

**(Reference)**

If a sine wave is input (track 2 on test disc YEDS 18), the B1 (MSB) waveform will be a short wave with a duty ratio of 50%.

**(Reference) 8-times oversampling**

In an 8-times oversampling digital filter, the data is sampled at 8-times the usual sampling frequency. At the normal 44.1kHz sampling rate, noise elements are generated at a frequency 20kHz below the sampling frequency, or 24.1kHz. In order to prevent this noise from passing through the analog filter, a very steep (300dB/oct.) filter must be used. A steep filter of this sort has a deleterious effect on the playback sound. The 8-times oversampling digital filter raises the sampling frequency to 352.8kHz. This, in turn, raises the frequency at which noise begins to 332.8 kHz, so an analog filter with a more gentle attenuation slope (18dB/oct.) can be used. The adverse effects on the playback sound typical of steep filters are eliminated. Waveforms following D/A conversion at the conventional sampling frequency and with 8-times oversampling are given in Figs. 12 and 13.

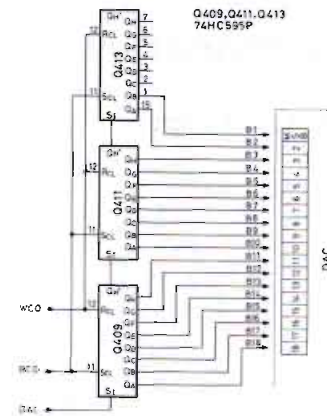

Fig. 11

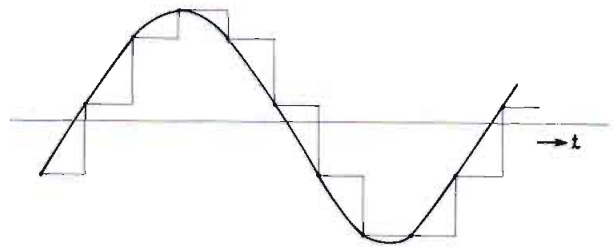

Fig. 12 Waveform following D/A conversion at conventional sampling frequency ( $F_s = 44.1\text{kHz}$ )

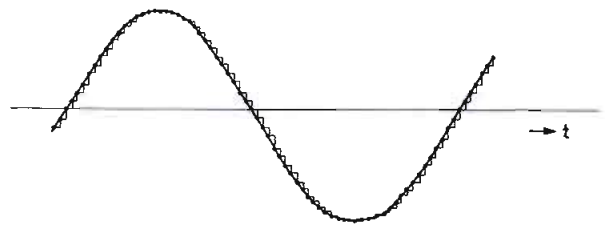

Fig. 13 Waveform following D/A conversion with 8-times oversampling ( $F_s = 352.8\text{kHz}$ )

Fig. 14 and 15 show the difference between the waveforms in Figs. 12 and 13 above on the frequency spectrum.

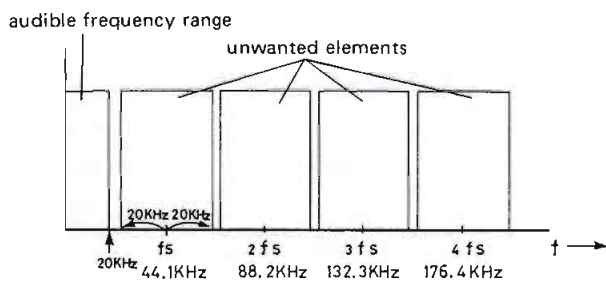

Fig. 14  $F_s = 44.1\text{kHz}$

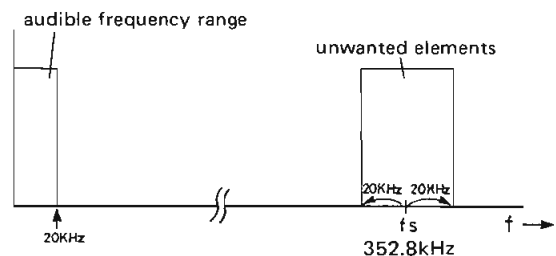
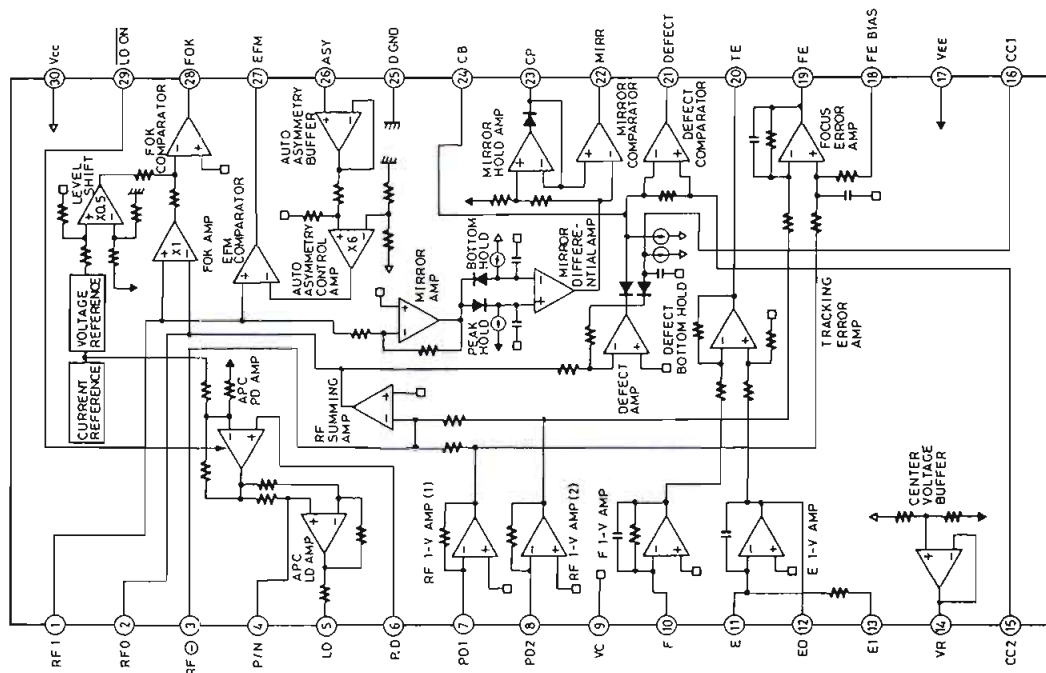

Fig. 15  $F_s = 352.8\text{kHz}$

# IC BLOCK DIAGRAM AND DESCRIPTIONS

## CXA1081M (RF Amp)



Pin No.	Symbol	Function	Pin No.	Symbol	Function
1	RF1	Input terminal of output signal of RF summing amplifier via the coupling capacitor	16	CC1	Defect bottom hold output terminal
2	RFO	Output terminal of RF summing amplifier	17	V <sub>EE</sub>	Negative power supply terminal
3	RF-	Input terminal of RF summing amplifier feedback	18	FE BIAS	Non-inversion bias terminal of focus error amplifier CMR adjustment of focus error amplifier
4	P/N	Switching terminal of P-SUB/N-SUB of LD (laser diode)	19	FE	Output terminal of focus error amplifier
5	LD	Output terminal of APC LD amplifier	20	TE	Output terminal of tracking error amplifier
6	PD	Input terminal of APC PD (Pin diode) amplifier	21	DEFECT	Output terminal of defect comparator
7	PD1	Inversion input terminal of RF I-V amplifier (1) Connect to A+C of PIN diodes.	22	MIRR	Output terminal of mirror comparator
8	PD2	Inversion input terminal of RF I-V amplifier (2) Connect to B+D of PIN diodes.	23	CP	Connection terminal of capacitor for mirror hold Non-inversion input of mirror comparator
9	VC	Connect to GND.	24	CB	Connection terminal of capacitor for defect bottom hold
10	F	Inversion input terminal of F I-V amplifier Connect to F of PIN diode.	25	DGND	Connect to GND
11	E	Inversion input terminal of E I-V amplifier Connect to E of PIN diode.	26	ASY	Auto asymmetry control input terminal
12	E0	Output terminal of E I-V amplifier	27	EFM	Output terminal of EFM comparator
13	E1	Feedback input terminal of E I-V amplifier Gain adjustment of E I-V amplifier	28	FOK	Output terminal of FOK comparator
14	VR	DC voltage output terminal of $(V_{CC} + V_{EE})/2$	29	LD ON	ON/OFF switching terminal of laser diode
15	CC2	Input terminal from defect bottom hold output signal via the coupling capacitor	30	V <sub>CC</sub>	Positive power supply

## CXA1082AQ (Servo Signal Processor)

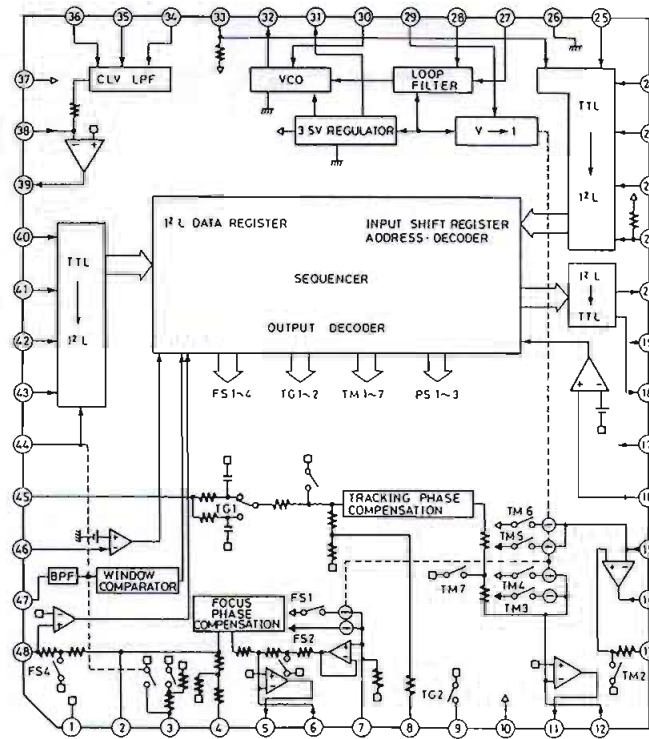

Pin No.	Symbol	Function	Pin No.	Symbol	Function
2	FGD	Insert the capacitor between this terminal and pin 3 when drop the high frequency gain of focus servo	28	PDI	Input terminal of phase comparator output PDO
3	FS3	Switching terminal of high frequency gain of focus servo	21	DIRCT	Input terminals for microcomputer and interface
4	FLB	Time constant switching terminal when raise the low frequency gain of focus servo	22	XRST	
5	FEO	Operation amplifier output terminals for power transistor drive	23	DATA	
11	TAO		24	XTL	
14	SLO		25	CLK	
39	SPDLO		33	LOCK	
6	FE-	Inversion input terminal of focus amplifier	29	ISET	Flow the current to decide the focus search, track jump, and kick height
7	SRCH	Time constant terminal to make the focus search waveform	30	VCOP	VCO free run frequency is proportion to resistor value between pins 30 and 31
8	TGU	Time constant terminal for high frequency gain switching of tracking	32	C864	VCO (8.64MHz) output terminal
9	TG2	Time constant terminal for high frequency gain switching of tracking	34	MDP	Connection terminal to terminal MDP of CXD1125QZ
12	TA-	Inversion input terminal of tracking amplifier	35	MON	Connection terminal to terminal MON of CXD1125QZ
13	SL+	Non-inversion input terminal of sled amplifier	36	FSW	LPF time constant terminal of CLV servo error signal
15	SL-	Inversion input terminal of sled amplifier	38	SPDL-	Inversion input terminal of spindle drive amplifier
16	SSTOP	Limit switch ON/OFF detector signal terminal for disc innermost position detector	40	WDCK	Input terminals for microcomputer and interface
17	FSET	Terminal of peak of phase compensation of focus tracking and of setting of LPF	41	FOK	
18	SENS	Output terminals for microcomputer and interface	42	MIRR	
20	C.OUT		44	DFCT	
27	BW	Time constant terminal of loop filter	45	TE	Tracking error signal input terminal
			46	TZC	Tracking zero cross comparator input terminal
			47	ATSC	Window comparator input terminal for ATSC detection
			48	FE	Focus error signal input terminal

**CXD1125QZ (Digital Signal Processor)**

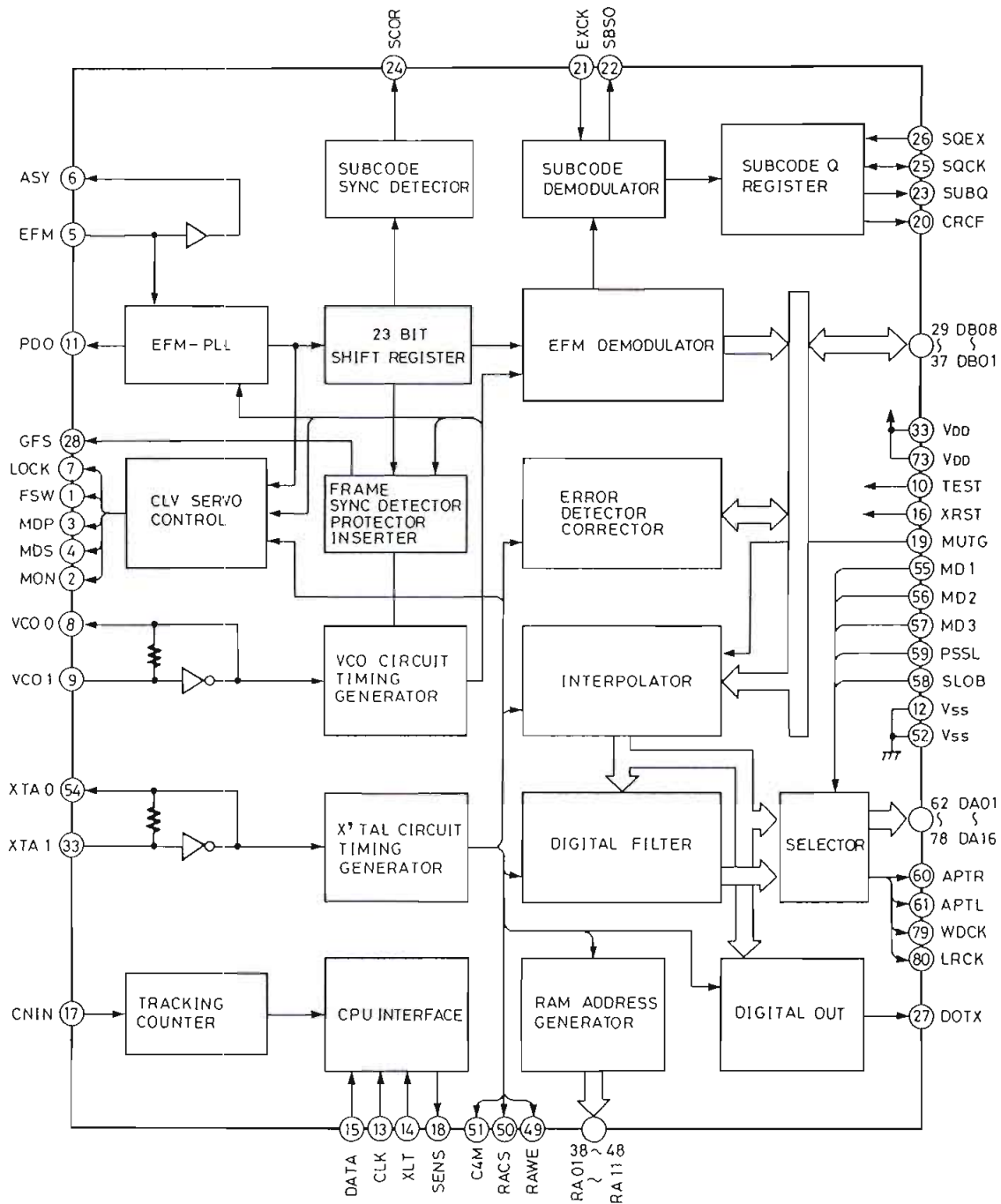

**74HC74P (D Flip-flop with preset)**

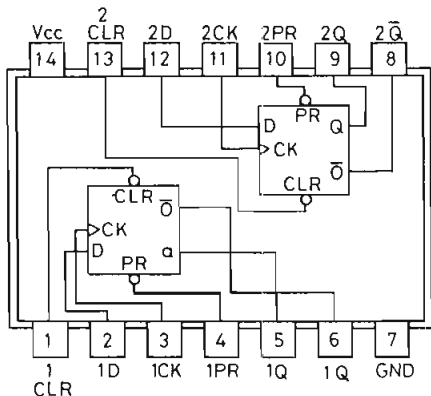

**74HC02 (NOR gates)**

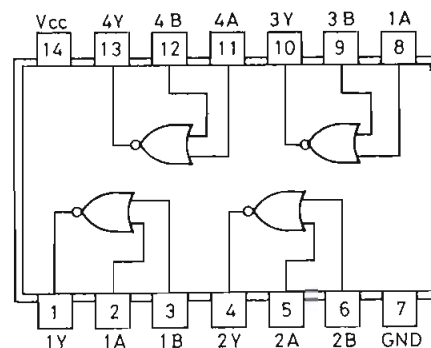



Pin No.	Symbol	Function	Pin No.	Symbol	Function
1	FSW	Time constant switching output terminal of output filter of spindle motor	49	RAWWE	Write enable signal output to external RAM
2	MON	ON/OFF control output terminal of spindle motor	50	RACS	Chip selector signal output to external RAM
3	MDP	Drive output terminal of spindle motor. Rough control when mode CLV-S and phase control when mode CLV-P	51	C4M	Divider output of crystal. f=4.2336MHz
4	MDS	Drive output terminal of spindle motor. Speed control when mode CLV-P	52	Vss	Ground
5	EFM	EFM signal input terminal from RF amplifier	53	XTAI	Input terminal of crystal oscillator
6	ASY	Output terminal to control the slice level of EFM signal	54	XTAO	Output terminal of crystal oscillator
7	LOCK	GFS sampling terminal	55	MD1	Mode switching input terminals
8	VCOO	VCO output terminal. 8.6436MHz when lock to EFM signal	57	MD3	
9	VCOI	VCO input terminal	58	SLOB	Code switching input of audio data output.
10	TEST	0V	59	PSSL	Mode switching input of audio data output. Serial output at low level. Parallel output at high level
11	PDO	Phase comparator output terminal of EFM signal and VCO/2	60	APTR	Control output for aperture correction. High level when Rch.
12	Vss	Ground	61	APTL	Control output for aperture correction. High level when Lch.
13	CLK	Serial data transmitter clock input terminal from microcomputer	62	DA01	DA01 (LSB of parallel sound output) output when PSSL = H. C1F1 output when PSSL = L
14	XLT	Latch input terminal from microcomputer	63	DA02	DA02 output when PSSL = H. C1F2 output when PSSL = L.
15	DATA	Serial data input terminal from microcomputer	64	DA03	DA03 output when PSSL = H. C2F1 output when PSSL = L.
16	XRST	System rest input terminal. Reset at low level.	65	DA04	DA04 output when PSSL = H. C2F2 output when PSSL = L.
17	CNIN	Tracking pulse input terminal	66	DA05	DA05 output when PSSL = H. C2FL output when PSSL = L.
18	SENS	Inner condition output terminal correspond to address	67	DA06	DA06 output when PSSL = H. C2PO output when PSSL = L.
19	MUTG	Muting input terminal	68	DA07	DA07 output when PSSL = H. RFCK output when PSSL = L.
20	CRCF	CRC check output terminal of subcode Q	69	DA08	DA08 output when PSSL = H. WFCK output when PSSL = L.
21	EXCK	Clock input terminal for serial output of subcode	70	DA09	DA09 output when PSSL = H. PLCK output when PSSL = L.
22	SBSO	Serial output terminal of subcode	71	DA10	DA10 output when PSSL = H. UGFS output when PSSL = L.
23	SUBQ	Subcode Q output terminal	72	DA11	DA11 output when PSSL = H. GTOP output when PSSL = L.
24	SCOR	Subcode sink S0 + S1 output terminal	73	V <sub>DD</sub>	Power supply (5V)
25	SQCK	Clock terminal to read the subcode Q	74	DA12	DA12 output when PSSL = H. RAOV output when PSSL = L.
26	SQEX	Selector input terminal of SQCK	75	DA13	DA13 output when PSSL = H. C4LR output when PSSL = L.
27	DOTX	Digital output terminal	76	DA14	DA14 output when PSSL = H. C210 output when PSSL = L.
28	GFS	Indicator output of lock condition of frame sync	77	DA15	DA15 output when PSSL = H. C210 output when PSSL = L.
29	DB08	Data terminals of external RAM	78	DA16	DA16 (MSB of parallel sound output) output when PSSL = H. DATA output when PSSL=L
32	DB05				
33	V <sub>DD</sub>	+5V	79	WDCK	Strobe signal output. 176.4kHz when DF is on. 88.2kHz when DF is off.
34	DB04	Data terminals of external RAM	80	LRCK	Strobe signal output. 88.2kHz when DF is on. 44.1kHz when DF is off.
37	DB01				
38	RA01	Address output terminals of external RAM			
48	RA11				

YM3414 (Eight times over sampling digital filter)

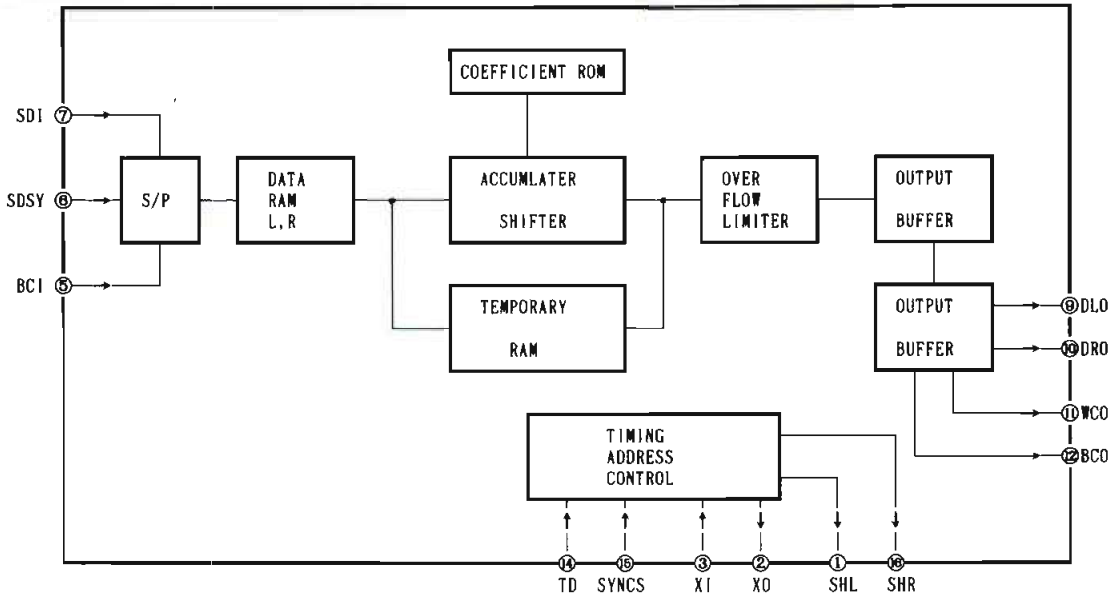

PIN NO.	TERMINAL	I/O	DESCRIPTION
1	SHL	O	When one DAC(TD=L):Deglitching signal of left channel (when four times) When two DAC(TD=H):Deglitching signal of left and right channels(when eight times)
2	XO	O	Connect the x'tal oscillator between XI and XO. The clock frequency is $384 \times F_s$ .
3	XI	I	
4	VDD2		+5V:Power supply terminal for x'tal oscillator and deglitching signal.
5	BCI	I	Bit clock input terminal. Clock shown L/Rch division of input data and input timing. 16 bits serial data input terminal.
6	SDSY	I	
7	SDI	I	
8	VDD1		+5V:Power supply terminal for digital signal.
9	DLO	O	When one DAC(TD=L):Output terminal for L/R channel data (When four times) When two DAC(TD=H):Output terminal for L channel data (when eight times)
10	DRO	O	R channel data output terminal. Word clock of output data DLO/DRO. Bit clock of output data.
11	WCO	O	
12	BCO	O	
13	VSS		Ground terminal
14	TD	I	1DAC/2DAC selector terminal: 1DAC at low. 2DAC at high.
15	SYNCS	I	Asynchronous input jitter absorption synchronous signal. Synchronous input at high level. SDSY inhibiting at low level.
16	SHR	O	R channel deglitching signal when one DAC.

NJM592D8 (Operation amp)

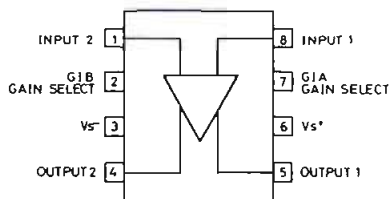

$\mu$ PC813C (Operation amp)

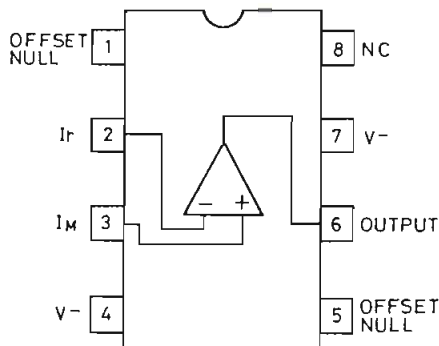

NJM5532DD (Operation amp)

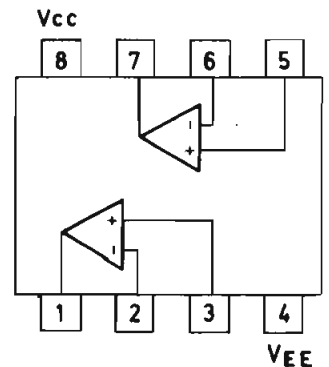

LC3517AS-15 (Static RAM)

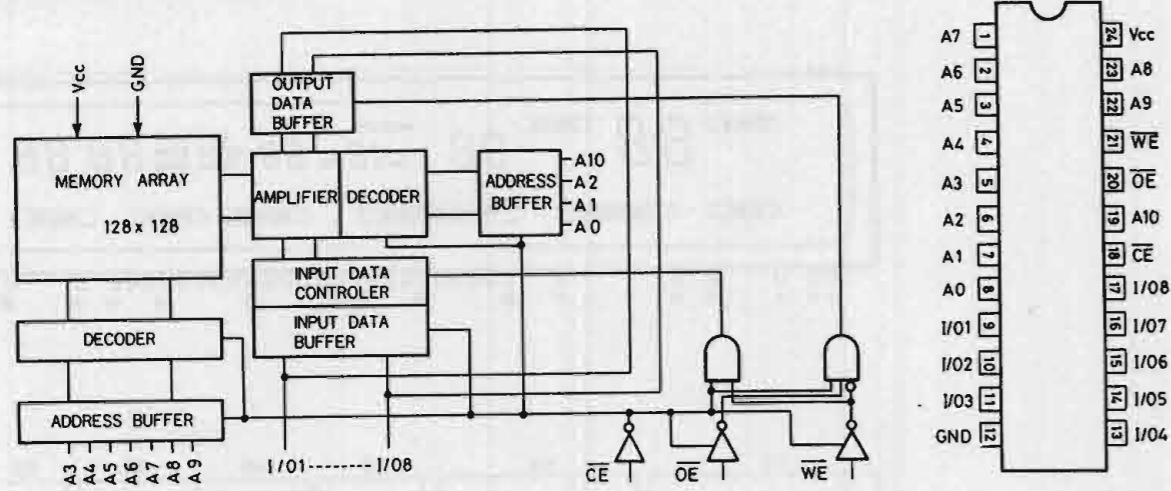

IR2406 (LED driver)

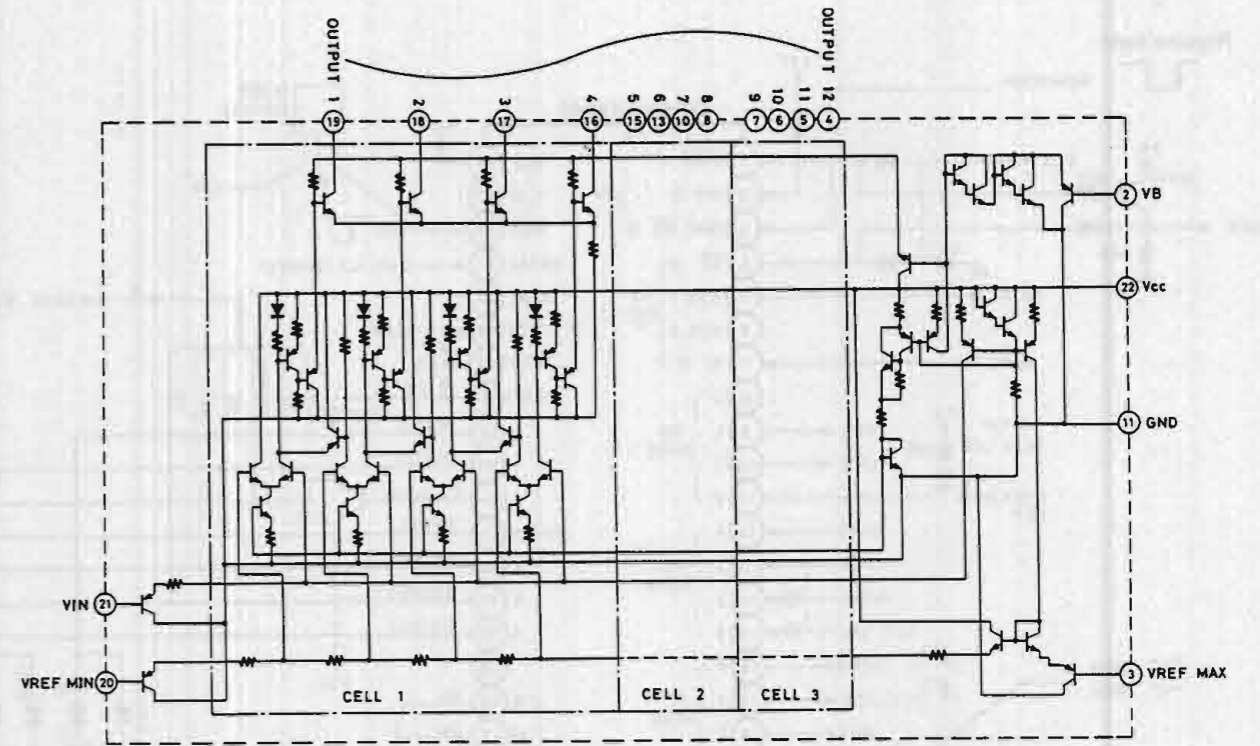

μPD4053BC (Analog Switch)

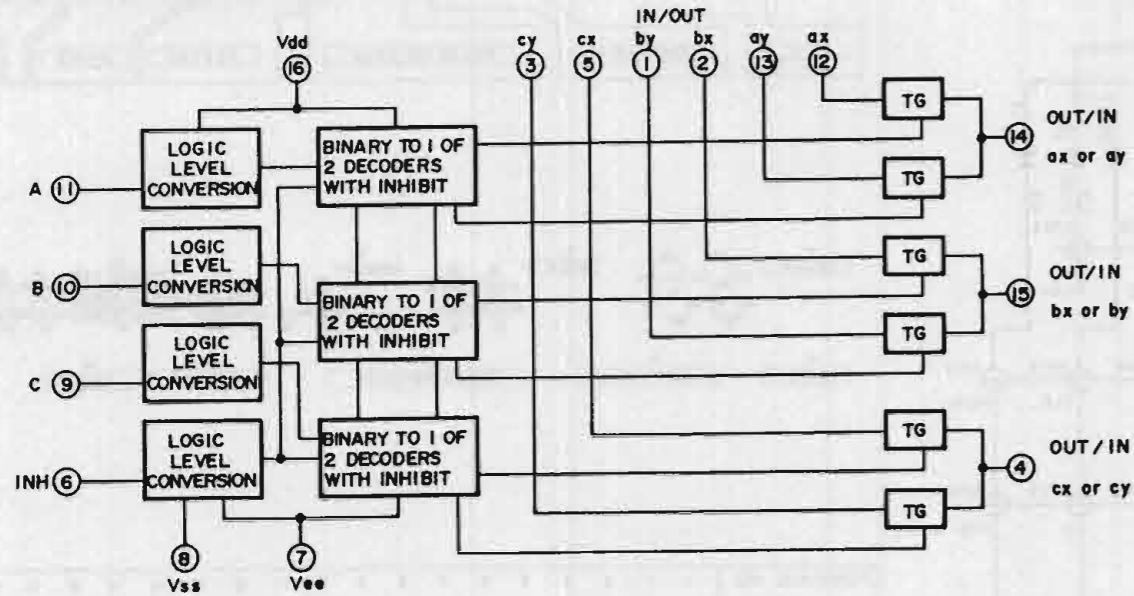

74HC595P (8 bits shift resistor)

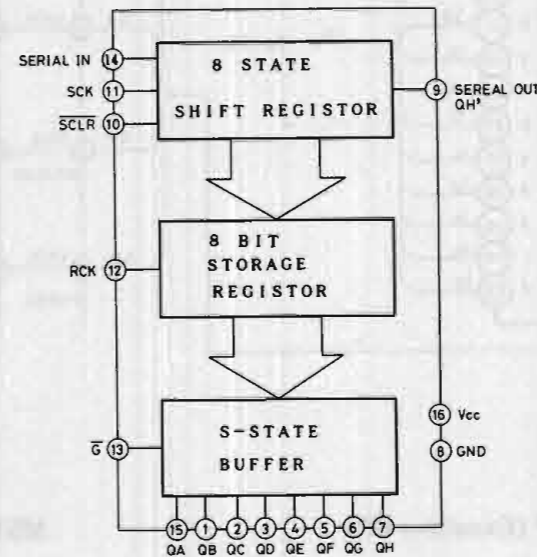

INPUTS					Resulting function
SI	SCK	SCLR	RCK	G	
X	X	X	X	H	Output QA-QH are in the high impedance state.
X	X	X	X	L	Latch Outputs, QA-QH, are enabled.
X	X	L	X	X	Shift register contents are cleared.
L	↑	H	X	X	A low logic level is shifted into the shift register.
H	↓	H	X	X	A high logic level is shifted into the shift register.
X	↓	H	X	X	Shift register remains unchanged.
X	X	X	↑	X	Shift register data stored in the 8-bit storage register.
X	X	X	↓	X	Storage register remains unchanged.

X: Don't Care

1. Output disable (QA-QH)
2. Output enable (QA-QH)
3. Clear the shift register

LB1630 (Motor Drive)

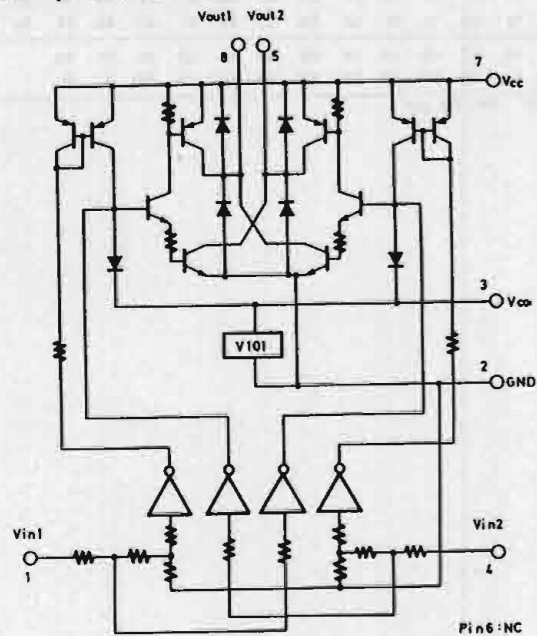

STA341M (Transistor Array)

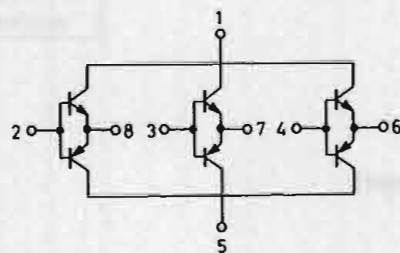

LA6500 (Power OP Amp)

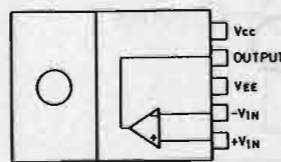

CXP5016H-229S (Microprocessor)

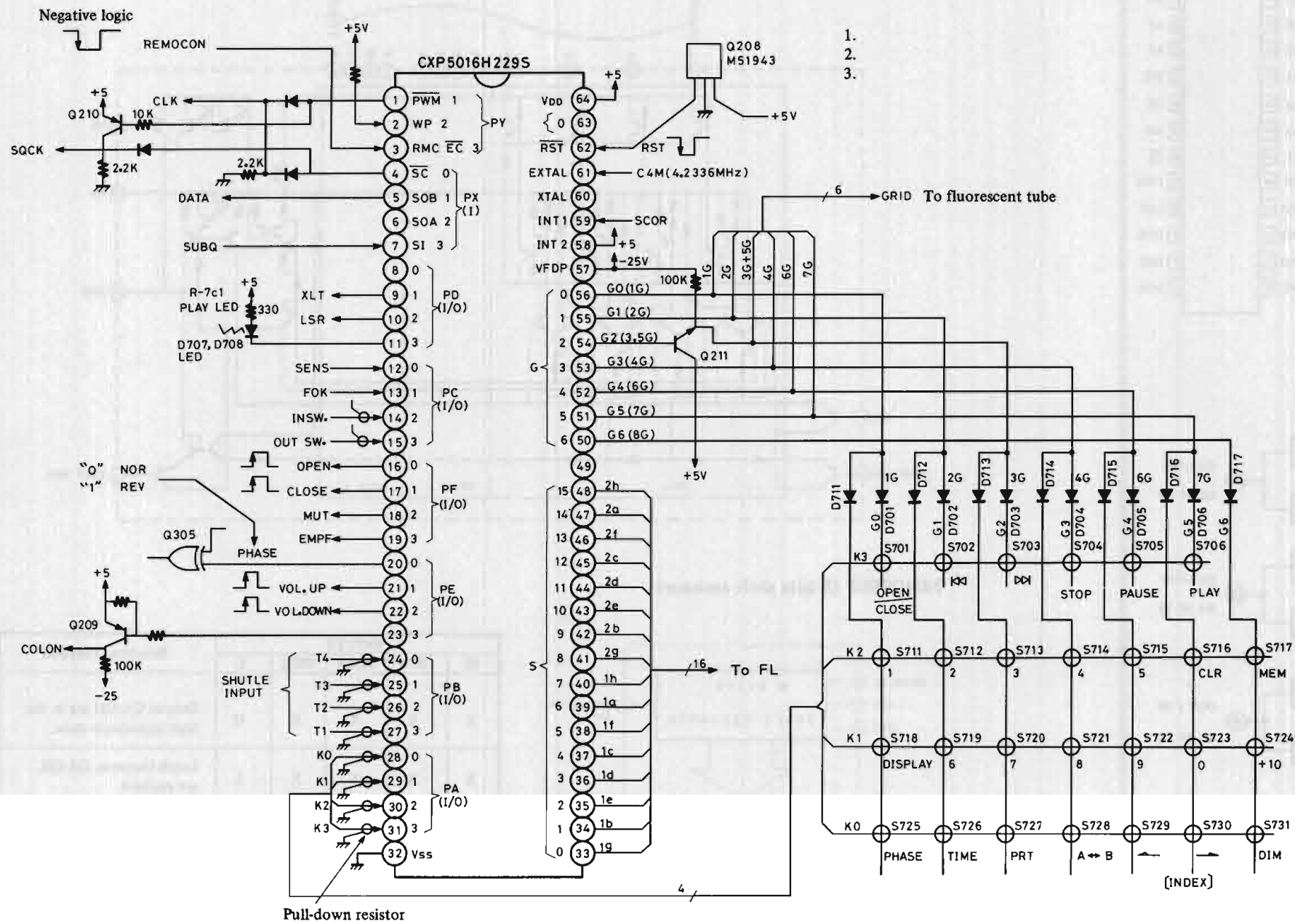

FIP13JM (Fluorescent tube)

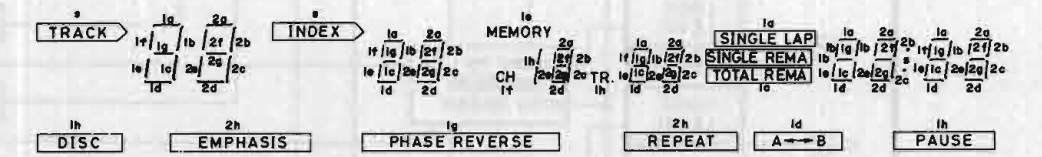
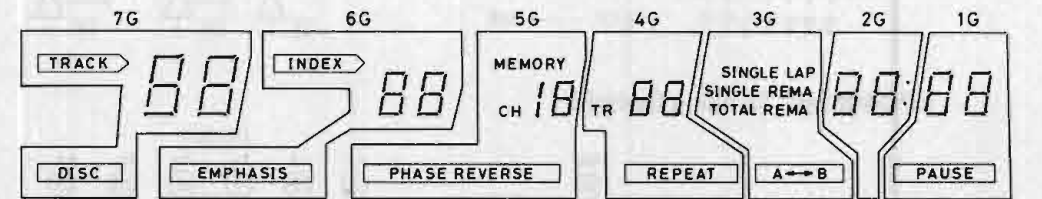
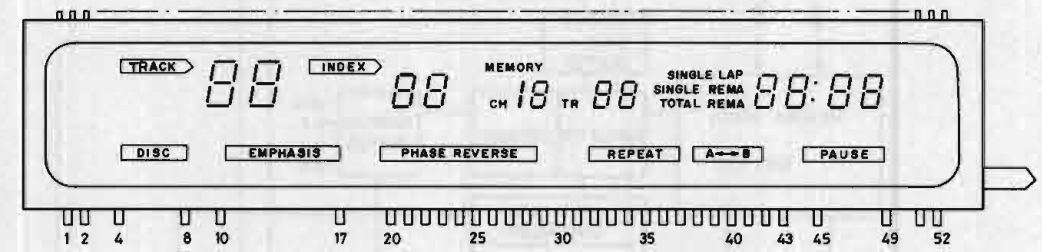

TERMINAL NO.	1	2	3	4	5	6	7	8	9	10	11	12	13	14	15	16	17	18
ELECTRODE	F	F	NP	7G	NP	NP	NP	7G	NP	6G	NP	NP	NP	NP	NP	NP	6G	NP
TERMINAL NO.	19	20	21	22	23	24	25	26	27	28	29	30	31	32	33	34	35	36
ELECTRODE	NP	5G	1g	1b	1e	1d	1c	1f	1a	5G	1h	2h	S	4G	2a	2f	2c	2d
TERMINAL NO.	37	38	39	40	41	42	43	44	45	46	47	48	49	50	51	52		
ELECTRODE	4G	3G	2e	2b	2g	3G	2G	NP	1G	NP	NP	NP	1G	NP	F	F		

Notes: F: Filament NP: No pin  
G: Grid

74HC04P (Hex inverter)

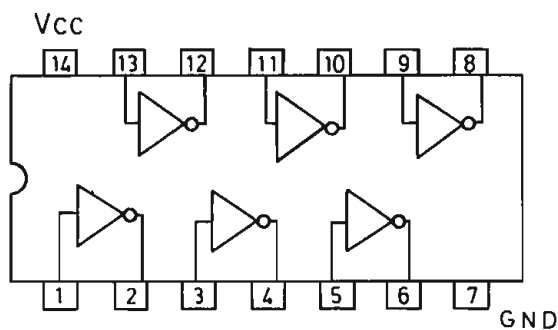

74HC86P (Exclusive OR)

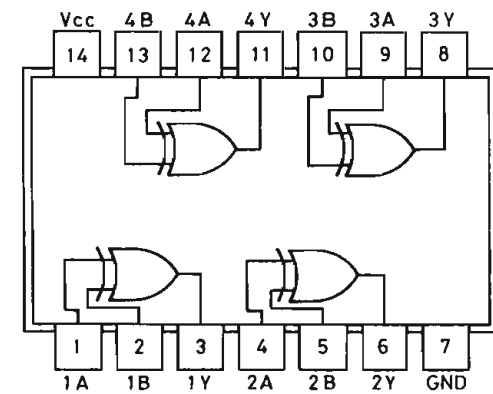

M51943ASL (System reset)

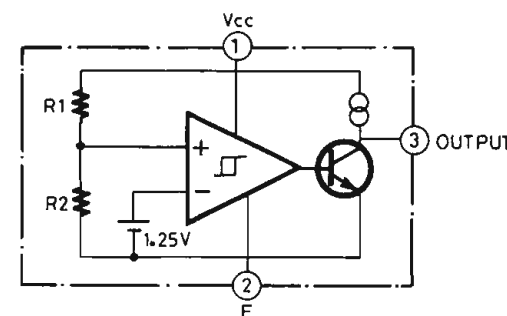

# ADJUSTMENT PROCEDURES

**Instruments required:** Dual trace oscilloscope (Use the high impedance probe: 10:1), Frequency counter, AF oscillator, AC voltmeter, Distortion analyzer, Insulated adjustment bar  
**Test disc (SONY : YEDS18), 4P socket P201 (Part No. 25050138)**

## Servo circuit adjustment

**Preparation:** Disconnect the five opto. fiber cables and Analog circuit pc board ass'y. (Refer page 6)

### 1. VCO frequency adjustment

Connect the frequency counter to test point PLCK.  
 Turn the power switch to ON (No load the disc).  
 Adjust R228 until the frequency counter reading becomes  $4.32 \pm 0.01$  MHz.  
 After adjustment, disconnect the frequency counter.

### 2. Tracking offset adjustment

Playback the track 2 of test disc.  
 Turn R204 to the minimum position (counterclockwise).  
 Connect the oscilloscope to pin 4 of plug P201.  
 Adjust RV102 until the center of tracking error signal on the oscilloscope becomes GND (Ground) level.  
 Turn R204 to the mechanical center.  
 After adjustment, disconnect the oscilloscope.

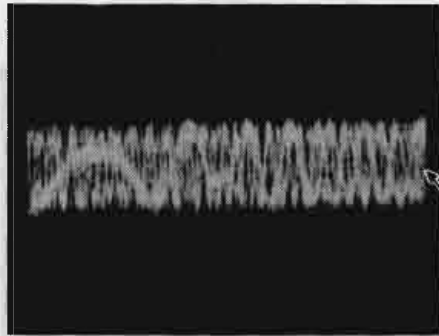

GND level  
 Photo 1  
 Range: Vertical: 0.5V/div.  
 Horizontal: 0.5mS/div.

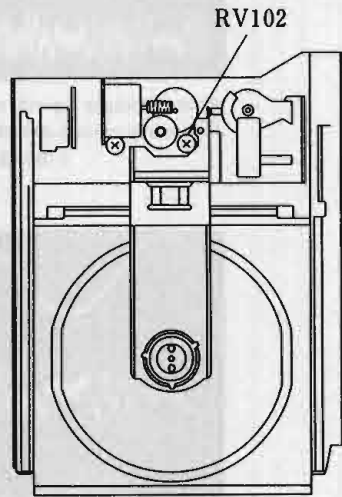

**Note:** The pickup moves to the outer edge of the disc and stops at 15 second intervals. When this happens, press the PLAY button again.

### 3. Focus gain adjustment

Set the output of AF oscillator to 800Hz, 1~1.5Vp-p.  
 Playback the track 2 of test disc.  
 Connect the oscilloscope and the AF oscillator as shown below.  
 Adjust R203 until the 800Hz components of channel 1 and 2 become the same level.  
 After adjustment, disconnect the oscilloscope and AF oscillator.



Photo 2  
 Range: Vertical: 0.2V/div.  
 Horizontal: 0.5mS/div.

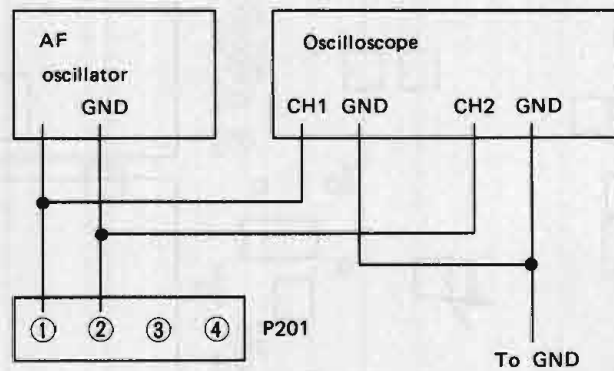

### 4. Tracking gain adjustment

Set the output of AF oscillator to 1.2kHz, 1~1.5Vp-p.  
 Playback the track 2 of test disc.  
 Connect the oscilloscope and the AF oscillator as shown below.  
 Adjust R204 until the 1.2kHz components of channel 1 and 2 become the same level.  
 After adjustment, disconnect the oscilloscope and AF oscillator.

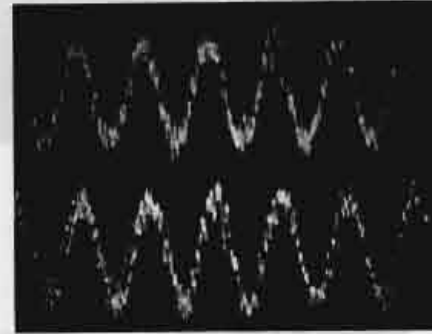
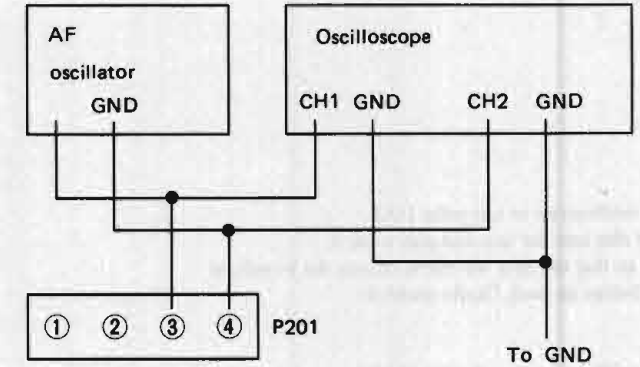
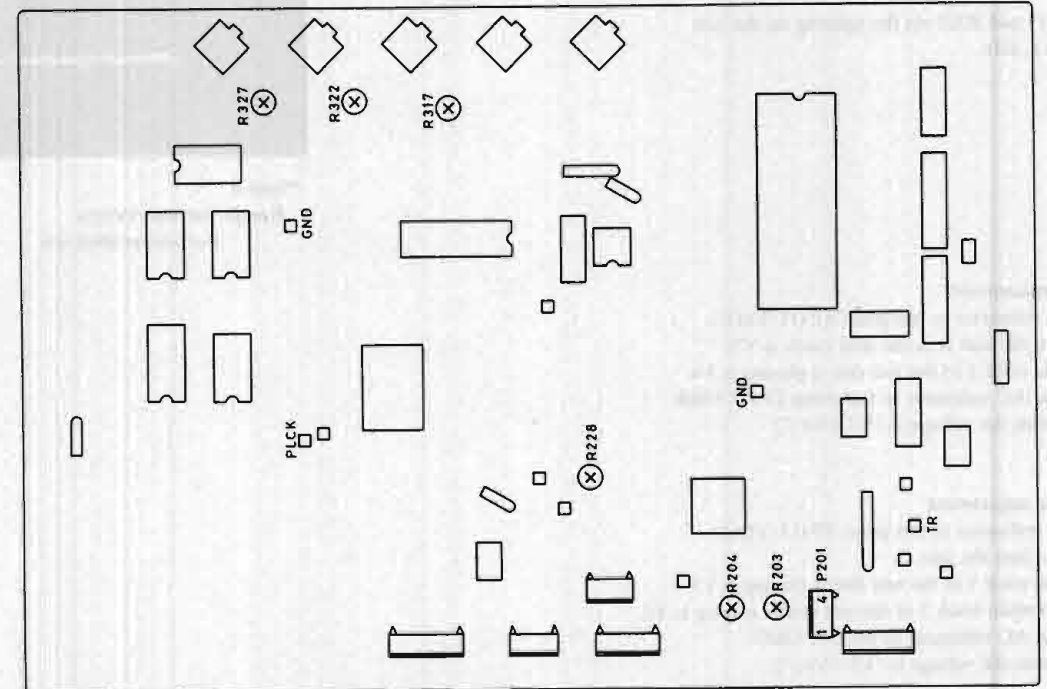

Photo 3  
 Range: Vertical: 0.2V/div.  
 Horizontal: 0.5mS/div



**NOTE:** After adjustment of servo circuit, connect the five opto. fiber cables and Analog circuit pc board ass'y.



### 2. Opto. transmitter circuit adjustment

Adjust after switching on more than 2 minutes.

#### 2-1 Bit clock adjustment

Connect the oscilloscope to test point BCK.  
 Adjust R327 so that the duty ratio of the waveform is 4.5:5.5.  
**NOTE:** Adjust R327 via the opening on the side bracket L side.

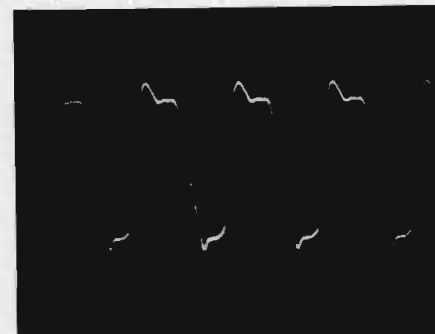
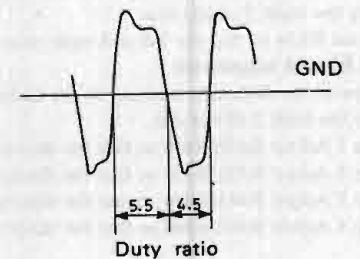

Photo 4  
 Range: Vertical: 1V/div.  
 Horizontal: 50nS/div.



**2-2 Word clock (WCK) adjustment**

Put the unit into the stop mode.

Connect the oscilloscope to test points WCK and BCK.

Adjust R411 so that there is a 50ns gap between the leading edge of WCK and that of BCK. (The BCK leading edge should come 50ns after the leading edge of WCK.)

(Refer photo 5)

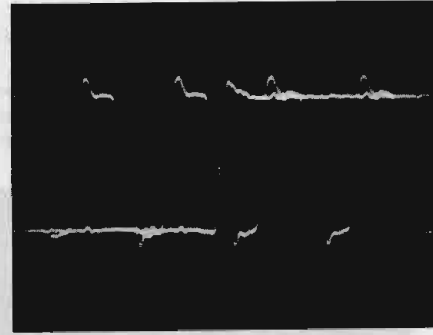

Photo 5  
Range:Vertical:1V/div.  
Horizontal:50nS/div.  
Synchronize with WCK.

Connect the oscilloscope to test point DAL.

Load the test disc into the unit and play track 2.

Adjust R317 so that the data waveform crosses the waveform immediately before its peak. (Refer photo 6)

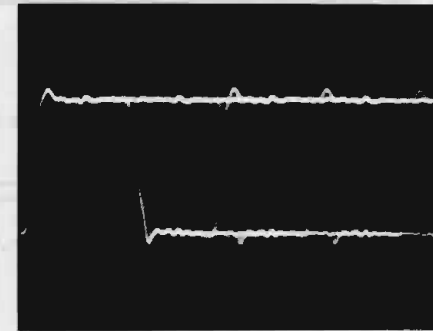

Photo 6  
Range:Vertical:1V/div.  
Horizontal:50nS/div.

Connect the oscilloscope to test point DAR.

Load the test disc into the unit and play track 2.

As above, adjust R322 so that the data waveform crosses the waveform immediately before its peak. (Refer photo 6)

Note: Adjust R317 and R322 via the opening on the side bracket L side.

**3. Muting level adjustment**

Connect the AC voltmeter to test point TP411 (VMU).

The voltage when the unit is in the stop mode is V3.

The voltage while track 1 of the test disc is playing is V4.

Next, connect the AC voltmeter to test point TP412 VMR.

Adjust R409 so that the voltage is  $(V3 + V4) / 2$

**4. Emphasis level adjustment**

Connect the AC voltmeter to test point TP413 (VEM).

Load the test disc into the unit.

The voltage while track 1 of the test disc is playing is V5.

Next, the voltage while track 2 of the test disc is playing is V6.

Next, connect the AC voltmeter to pin 6 of Q407.

Adjust R418 so that the voltage is  $(V5 + V6) / 2$ .

**5. D/A converter adjustment****5-1. Audio output level adjustment**

Connect the AC voltmeter to test point TP403.

Adjust R433 so that the voltage is  $10.00 \pm 0.03V$ .

Connect a 2needle AC voltmeter to the audio output (FIXED) terminals.

Play the track 2 of test disc.

Adjust R434 so that the left and right channel output levels are the same.

**5-2. B1~B4 adjustment**

Connect the distortion analyzer to the audio output (FIXED) terminals.

Play the track 2 of test disc.

Step 1 Adjust R439/R440 so that the distortion analyzer reading is minimum. (Refer photo 7)

Step 2 Adjust R435/R436 so that the distortion analyzer reading is minimum. (Refer photo 8)

Step 3 Adjust R443/R444 so that the distortion analyzer reading is minimum. (Refer photo 9)

Step 4 Adjust R447/R448 so that the distortion analyzer reading is minimum. (Refer photo 10)

Step 5 Repeat the steps 1,2,3 and 4 until no further adjustment is necessary.

Note 1: Synchronizing the distortion waveform with the signal on the oscilloscope makes it easier to observe.

2: Turn both 400Hz HPF and 30kHz LPF on the distortion analyzer ON.

Reference: The audio output offset voltage (voltage at R511, R512 adjustment point arrows) in the stop mode should be less than 10mV.

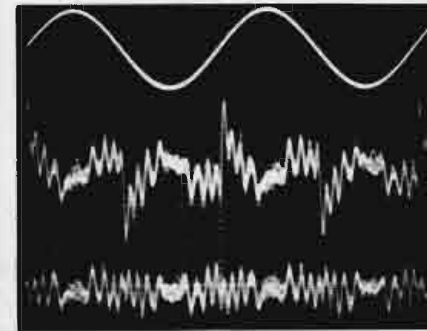

Photo 7 Output waveform  
Distortion ratio: 0.00668%  
0.00324%

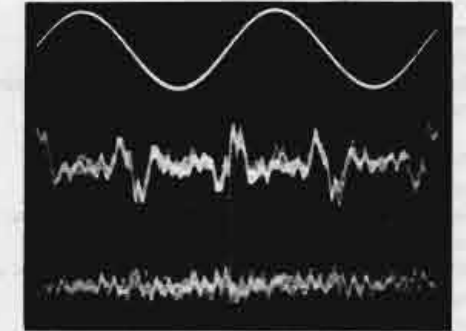

Photo 8 Output waveform  
Distortion ratio: 0.00435%  
0.00213%

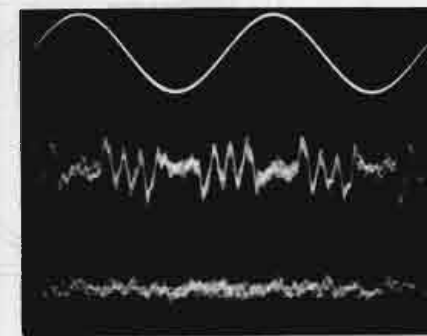

Photo 9 Output waveform  
Distortion ratio: 0.00362%  
0.00186%

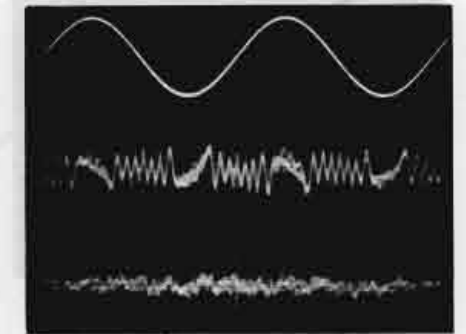
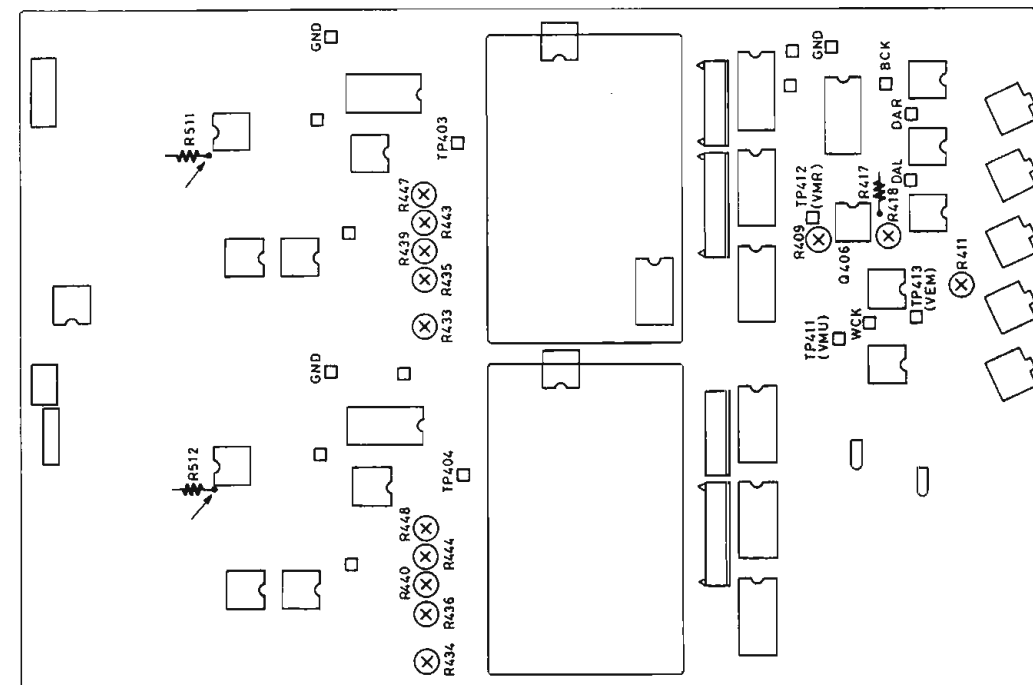
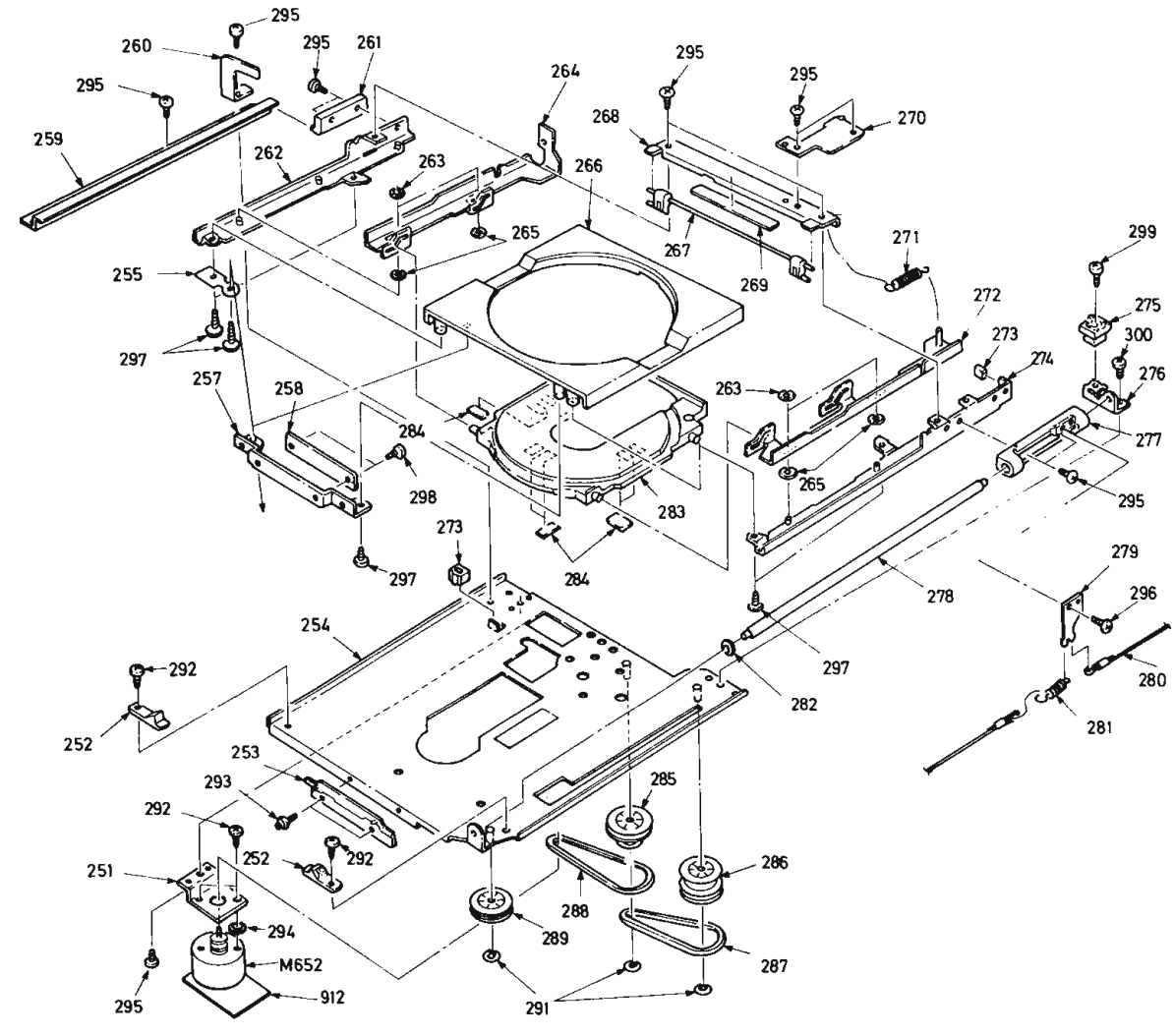
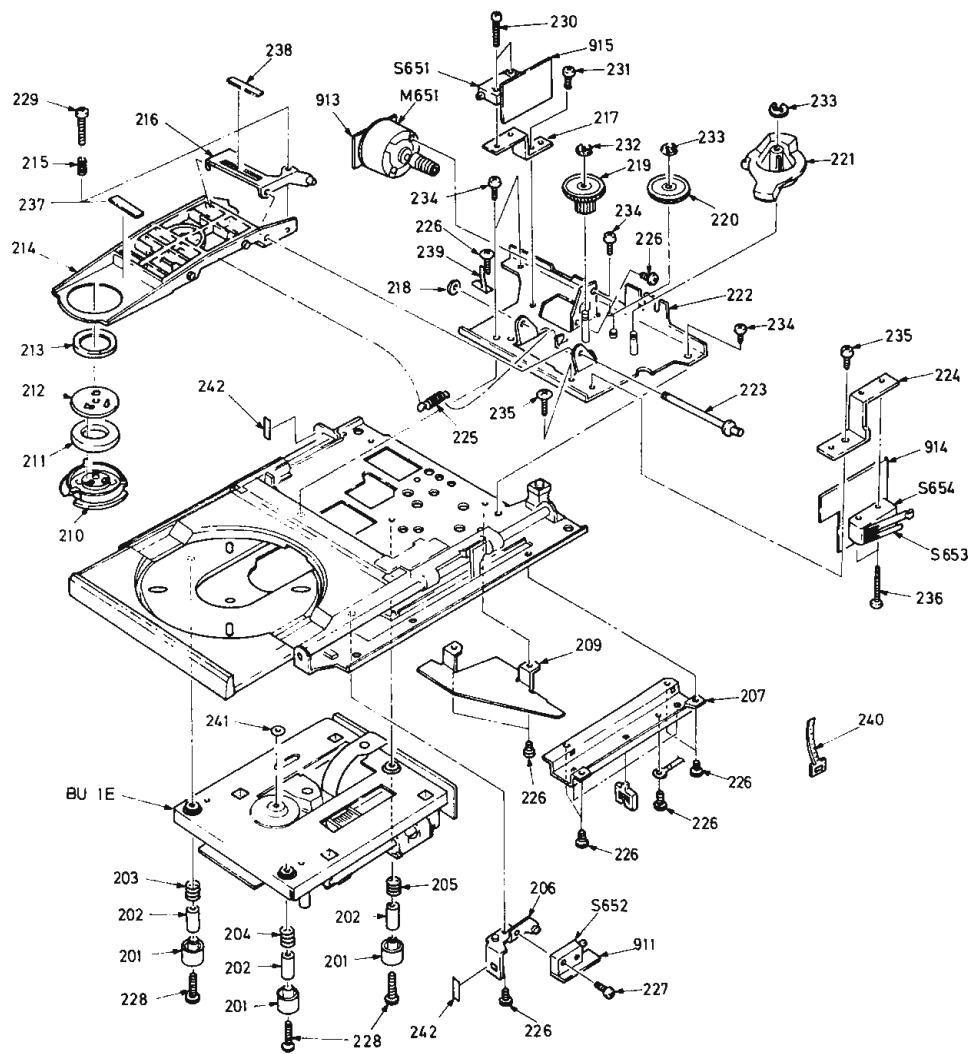

Photo 10 Output waveform  
Distortion ratio: 0.00335%  
0.00186%



# MECHANISM EXPLODED VIEW



REF.NO.	PART NO.	DESCRIPTION	REF.NO.	PART NO.	DESCRIPTION
201	27190580	Holder	228	82543020	3B + 20FN(BC), Binding screw
202	27270225	Spacer	229	82542616	2.6B + 16F(BC), Binding screw
203	27180367	Spring G	230	834126107	2.6TTS + 10S, Tapping screw
204	27180368	Spring S	231	801393	3SMPSW + 5FN, Sems screw
205	27180369	Spring B	232	8930502	E-5, Circlip
206	27141170	Bracket, switch C	233	8930301S	ES-3S, Circlip
207	27130509	Bracket RO	234	834130057	3TTS + 5S, Tapping screw
209	27141171	Bracket, belt	235	82543003	3B + 3FN(BC), Binding screw
210	27301041	Cap CH	236	82112314	2.3P + 14F, Pan head screw
211	27301042	Magnet	237	27301061	Sheet C
212	27301043	York	238	27301062	Sheet B
214	27301044	Arm ass'y	239	27180372	Spring, ground
215	27180370	Spring	240	260208	Binder
216	27301045	Adjustment plate	241	27270226	Spacer D
217	27141172	Bracket, switch D	242	28140783	Cushion
218	27270227	Washer	911	25133171	NCSW-3171, Pc board
219	27301046	Gear A	913	25133173	NCETC-3173, Pc board
220	27301047	Gear B	914	25133174	NCSW-3174, Pc board
221	27301048	Cam gear	915	25133175	NCSW-3175, Pc board
222	27100148	Sub-chassis	M651	24502223	Motor ass'y
223	27260238	Shaft arm	S651	25065329	NMS-1216, Microswitch
224	27141192	Bracket, switch C	S652	25065329	NMS-1216, Microswitch
225	27180371	Spring arm	S653	25065330	NMS-1217, Microswitch
226	82542603	2.6B + 3F(BC), Binding screw	S654	25065331	NMS-1218, Microswitch
227	82112608	2.6P + 8F, Pan head screw			

REF.NO.	PART NO.	DESCRIPTION	REF.NO.	PART NO.	DESCRIPTION
251	27141173	Bracket, motor	277	27267525	Guide, shaft
252	27267524	Guide	278	27260239	Shaft
253	27141193	Holding bracket ass'y	279	27141182	Bracket RO
254	27100149	Chassis	280	273907	Rope
255	27141174	Bracket, ground	281	27180374	Spring RO
257	27141175	Bracket L	282	28140784	Cushion A
258	27262465	Plate	283	27301054	Disc holder ass'y
259	27141176	Bracket, guide	284	27301064	Sheet
260	27141177	Bracket, holder	285	27301055	Pulley A
261	27267526	Guide S	286	27301056	Pulley C
262	27141194	Mounting bracket L ass'y	287	27301067	Belt A
263	27270227	Washer	288	27301068	Belt B
264	27301049	Cam plate L	289	27301057	Pulley B
265	27270229	Poly washer	291	8930301S	Circlip
266	27301051	Disc table	292	82542603	Screw
267	27301052	Lever	293	801394	+PSW2.6 x 8, Special screw
268	27141178	Bracket, table	295	834130057	3TTS + 5S, Tapping screw
269	27301063	Sheet S	296	83812055	2.6STB + 5B, Tapping screw
270	27141179	Bracket W	297	838130082	3STB + 8BQ, Tapping screw
271	27180373	Spring D	298	838126057	2.6TTB + 5S, Tapping screw
272	27301050	Cam plate R	299	838130167	3TTB + 16S, Tapping screw
273	27301066	Cushion rubber	300	801393	3SMPSW + 5FN, Sems screw
274	27141180	Bracket R	912	25133172	NCETC-3172, Pc board
275	27301053	Stopper T	M652	24502224	Motor ass'y
276	27141181	Bracket, shaft			

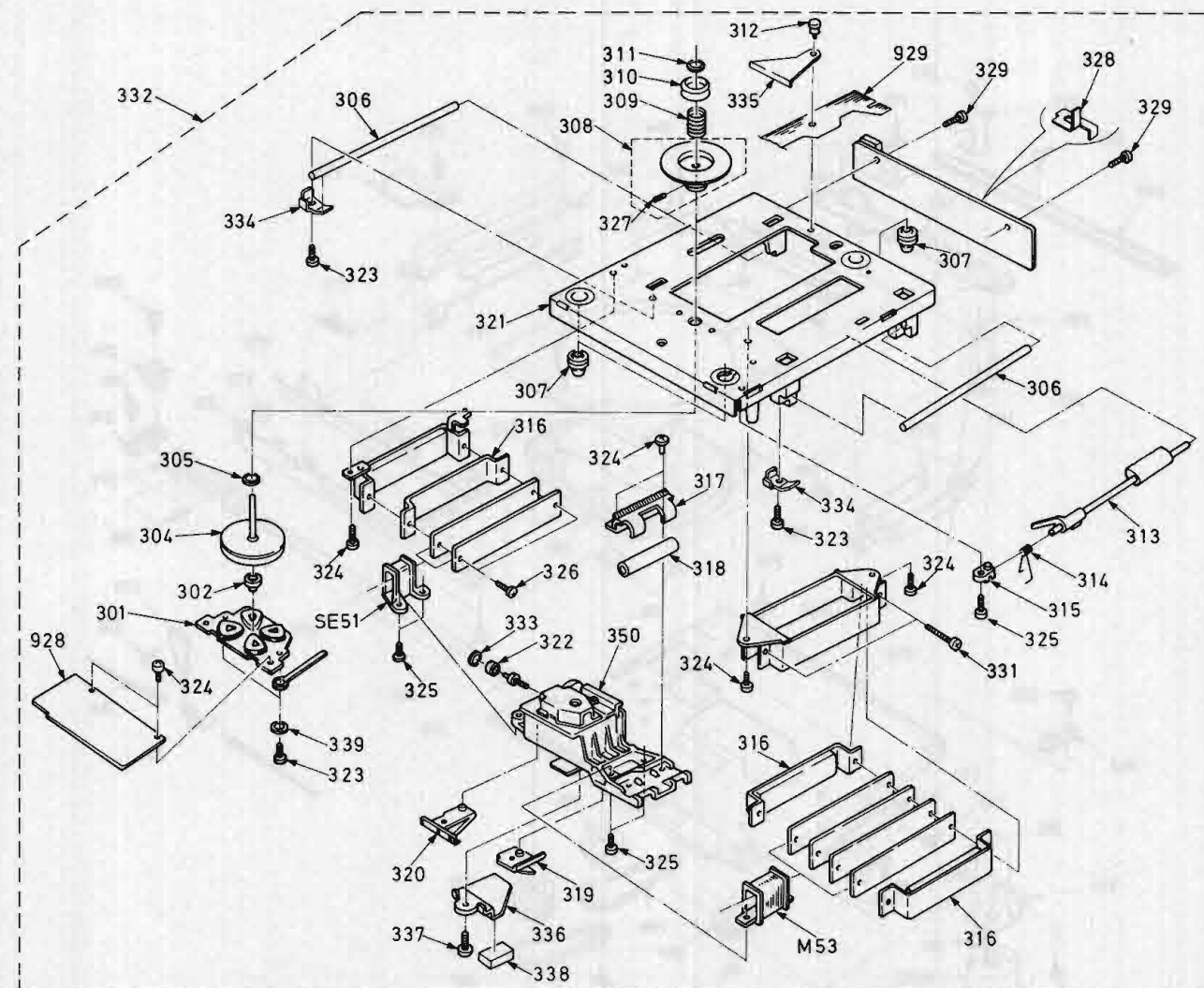

## CHASSIS- PARTS LIST

REF.NO.	PART NO.	DESCRIPTION	REF.NO.	PART NO.	DESCRIPTION
BU-1	24506746	CD drive unit	321	27100150	Chassis PU
301	27141183	Bracket M	322	27301075	Ball bearing
302	27301058	Thrust holder	323	833426082	2.6STP+8BQ, Tapping screw
304	27301059	Rotor ass'y	324	82542604	2.6B+4F(BC), Binding screw
305	27270228	3,Poly washer	325	82542605	2.6B+5F(BC), Binding screw
306	27260240	Shaft PU	326	838126087	2.6TTB+8S,Tapping screw
307	27301069	Cushion rubber	327	801395	2.6×3WP,Screw
308	27301060	Turntable	329	838126107	2.6TTB+10S, Tapping screw
309	27180375	Spring	331	838126167	2.6TTB+16S, Tapping screw
310	27301065	Center ring cap	333	8930232	E-2.3Zn, Circlip
311	27270227	Washer	334	27141184	Bracket SL
312	880016	NRP-335, Rivert	335	27301076	Holder PB
313	27301070	Locking lever	336	27141185	Bracket PB
314	27180376	Spring RL	337	82543006	3B+6FN(BC), Binding screw
315	27190586	Holder ROD	338	28140785	Cushion PB
316	27301071	Liner york ass'y	339	870142	W2.6×7F, Washer
317	27190581	Holder BR	928	25133176	NCETC-3176, Pc board
318	27301072	Bearing	929	25133177	NCETC-3177A, Flexible pc board
319	27301073	Lead wire holder A	M53	24502225	Coil D
320	27301074	Lead wire holder B	SE51	24502226	Coil S

REF.NO.	PART NO.	DESCRIPTION	REF.NO.	PART NO.	DESCRIPTION
A001	27100147A	Chassis	A501	1H046121UD	Front panel ass'y <D/W/PX>
A002	27115231B	Side bracket L		1H046121UG	Front panel ass'y <G>
A003	27115232B	Side bracket R	A506	28135125	Badge
A004	27110385A	Front bracket	A509	27210971	Tray panel <D/W/PX>
A005	27141165	Bracket,headphone		27210972	Tray panel <G>
A006	27130505A	Bracket,power transformer	A510	27267521	Guide,knob
A007	27150255	Shielded plate,power	A511	28400361A	Lid
A008	27150242	Shielded plate	A512	1H031702	Bearing L ass'y
A009	27140881-1	Bracket S	A516	27301040A	Bearing R
A010	27190648	Holder ass'y <D/W/PX>	A517	27141268A	Bracket,ground
	27190652	Holder ass'y <G>	A519	27210974	Front panel,door <D/W/PX>
A011	27130510	Bracket,pc board		27210907	Front panel,door <G>
A012	27190588	Holder,lid	A520	27141169A	Bracket,door
A013	27190589	Holder,bottom	A524	27270254	Spacer
A014	27130525	Bracket B	A525	28140804	Cushion
A015	27150246	Shielded plate	A526	28140755	t0.5×6×165,Cushion
A016	28191442	Clear plate	A527	28140756	t0.5×30×30,Cushion
A017	28133201	Back plate	A528	28140672A	t1.5×158×190,Cushion
A019	27273065	Joint	A529	28140126	t0.5×53, Cushion
A020	27262470	Plate	A532	28140827	t6×10×40, Cushion
A021	27141236A	Bracket SH	A533	28140828	t1×4×10,Cushion
A022	27150249	Shielded plate	A534	28140829	t1×5×40,Cushion
A023	27121140	Back panel <D>	A535	29110075	Copper tape
	27121141	Back panel <G>	A536	28140900	t0.5×6×15, Cushion
	27121143A	Back panel <W/PX>	A537	27270260	t4×15×15,Spacer
A025	27300750	△ Strainrelief	A538	27270261	t5.5×15×15,Spacer
A026	27150247	Shielded plate CD	A540	834430068	3TTS+6B(BC),Tapping screw
A027	27141228	Bracket CD	A541	835430065	3STF+6B(BC),Flat head tapping screw
A028	28140793	Cushion	A542	833430080	3TTP+8P(BC),Tapping screw
A029	27270243	Spacer	A543	82142604	2.6P+4F(BC),Pan head screw
A030	834430068	3TTS+6B(BC),Tapping screw	A544	84643008	3HSB×8FN(BC),Hexagonal head bolt
A032	831130088	3TTW+8B,Tapping screw	A545	870071	WW6,Wave washer
A033	830440089	4TTC+8C(BC),Tapping screw	A601	27175171A	Leg
A034	87313006	M-3B,Toothed washer	A603	27141168	Bracket D
A035	801230	3STS+8BQ(BC),Tapping screw	A604	27141167	Bracket ST
A036	28140814	t1.5×55×30,Cushion	A605	834430068	3TTS+6B(BC),Tapping screw
A037	28140815	t1.5×100×30,Cushion	A606	834230108	3TTS+10B(Ni),Nickel screw
A038	28140816	t1.5×160×80,Cushion	A607	834440168	4TTS+16B(BC),Tapping screw
A039	28140853	Cushion	A608	87314006	M-4B,Toothed washer
A040	28140817	t4.5×55×10,Cushion	A801	28323185A	Knob SH
A041	28175149	Insulated plate	A802	28323186A	Knob POWER
A042	29110050	12×340,Aluminium tape	A803	28323393	Knob TEN <D/W/PX>
A043	834430088	3TTS+8B(BC),Tapping screw		28323187	Knob TEN <G>
A044	838426088	2.6TTB+8B(BC),Tapping screw	A804	28323394	Knob PE <D/W/PX>
A045	831430088	3TTW+8B(BC),Tapping screw		28323188-1	Knob PE <G>
A046	880011	NRP-355,Rivert	A805	28323188-2	Knob D
A047	28140897	t12×35×180, Cushion	A806	28323188-3	Knob S
A048	28140898	t1.5×140×70,Cushion	F301-F305	241058	FCPA00001AF,Photo coupler
A049	28140899	t8×70×70,Cushion	P801	253112A	△ AS-UC-4 #18,Power supply cord <D/PX>
A051	28140820	Cushion		253148 or	△ AS-CEE,Power supply cord <G/W>
A052	28140821	Cushion,disc		253150	
A055	29355142	Caution label	S801	25000004	SRGP-S-001,Encoder
A056	29360911	Label,LASER 3	S902	25065195	△ NSS-1288P,Voltage selector switch <W>
A301	28145124	Top panel B	SC151	2000766A	NSAS-4P722,Socket
A302	28145125A	Top panel F	SC651	2000767A	NSAS-7P723,Socket
A303	27141153A	Bracket T	T911	2300295	△ NPT-981D,Power transformer <D>
A304	801403	5×12(BC),Special screw		2300296	△ NPT-981G,Power transformer <G>
A305	27265159	Decoration ring F		2300375	△ NPT-981AG,Power transformer <W/PX>
A306	834430068	3TTS+6B(BC),Tapping screw	T951	2300299	△ NPT-982D,Power transformer <D>
A308	28140812	t5×25×300,Cushion		2300300	△ NPT-982G,Power transformer <G>
A309	1H046602	Side panel L ass'y		2300374	△ NPT-982AG,Power transformer <W/PX>
A310	1H046603	Side panel R ass'y	U1	1H046560-3	NADG-3160-3,Digital circuit pc board ass'y <D/W/PX>
A311	870086	4×12(BC),Special washer		1H046560-3A	NADG-3160-3a,Digital circuit pc board ass'y <G>
A312	836440303	4STV+30CQ(BC),Special screw	U2	1H046561-2	NADIS-3161-2,FL tube circuit pc board ass'y
A313	87314006	M-4B,Toothed washer	U3	1H046530-2	NADIS-3230-2,Level indicator pc board ass'y



# CHASSIS-EXPLODED VIEW

REF.NO.	PART NO.	DESCRIPTION
U4	1H046563-2	NADIS-3163-2,Remote control pc board ass'y
U5	1H046564-2	NAPS-3164-2,Power supply circuit pc board ass'y
U6	1H046565-2	NASW-3165-2,Operation switch pc board ass'y
U7	1H046566-3	NAAF-3166-3,Analog circuit pc board ass'y
U8	1H046567-2	NAAF-3167-2,Output terminal pc board ass'y
U9	1H046568-2	NAAF-3168-2,Headphone terminal pc board ass'y
U10	1H046570-2	NAAF-3170-2,Power supply pc board ass'y
U12	1H046506-2	NAAF-3206-2,Power supply pc board ass'y
W1	260208	Binder
Z1	24506735	CD mechanism ass'y

NOTE: THE COMPONENTS IDENTIFIED BY MARK  ARE CRITICAL FOR RISK OF FIRE AND ELECTRIC SHOCK. REPLACE ONLY WITH PART NUMBER SPECIFIED.

NOTE: <D>:Only 120V model  
 <G>:Only 220/240 model  
 <W>:Only Worldwide model  
 <PX>:Only PX model

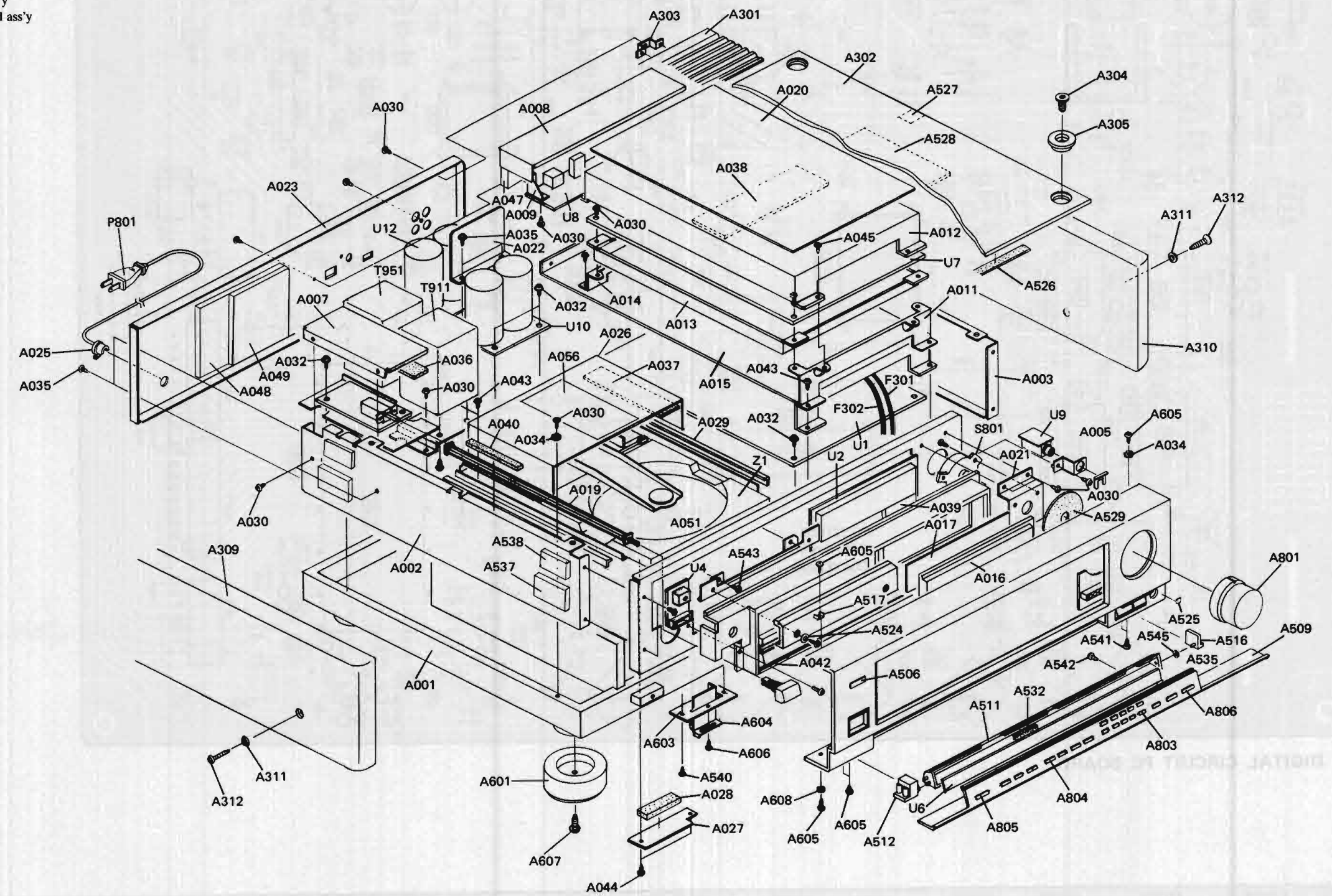

PRINTED CIRCUIT BOARD VIEW FROM BOTTOM SIDE

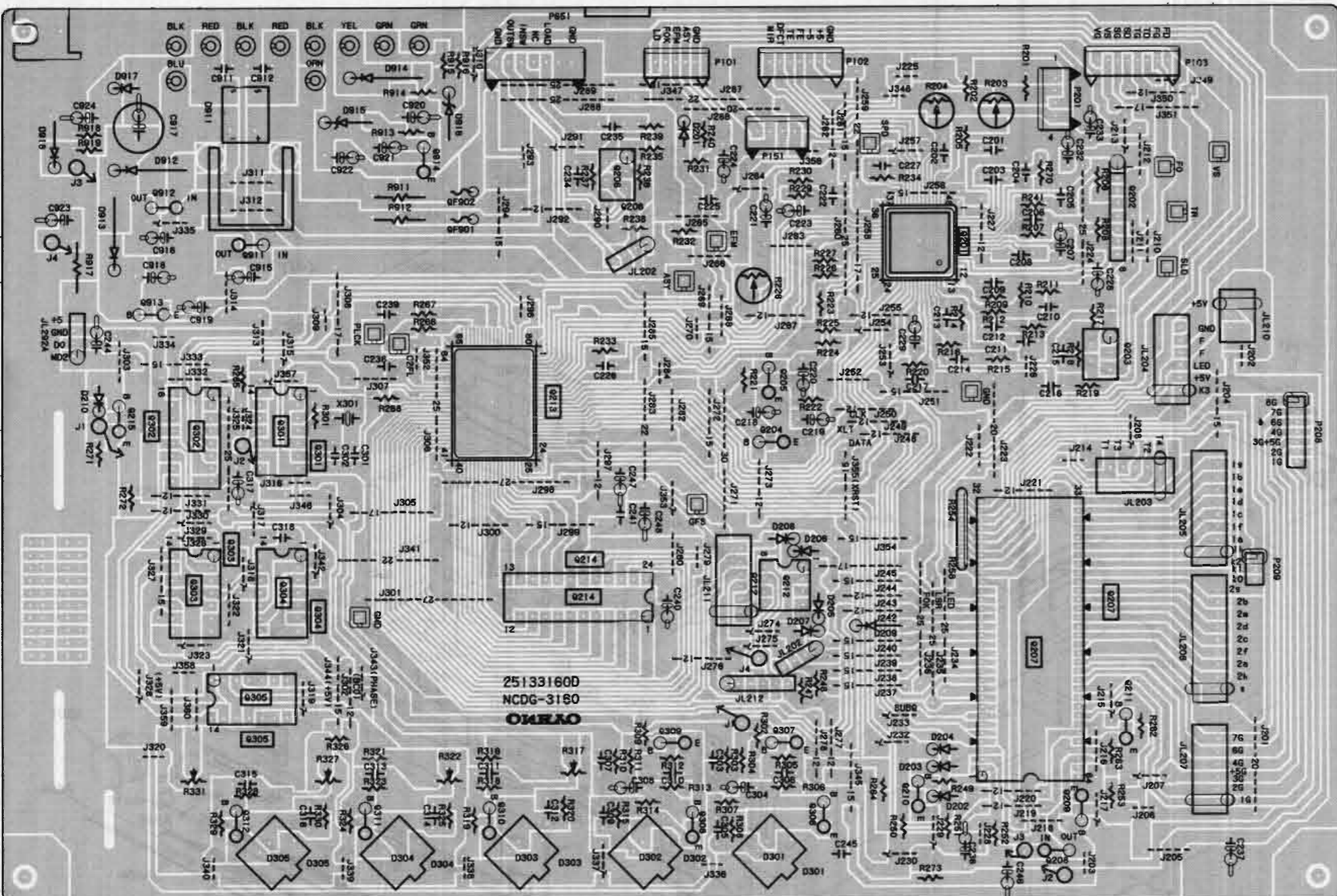

DIGITAL CIRCUIT PC BOARD

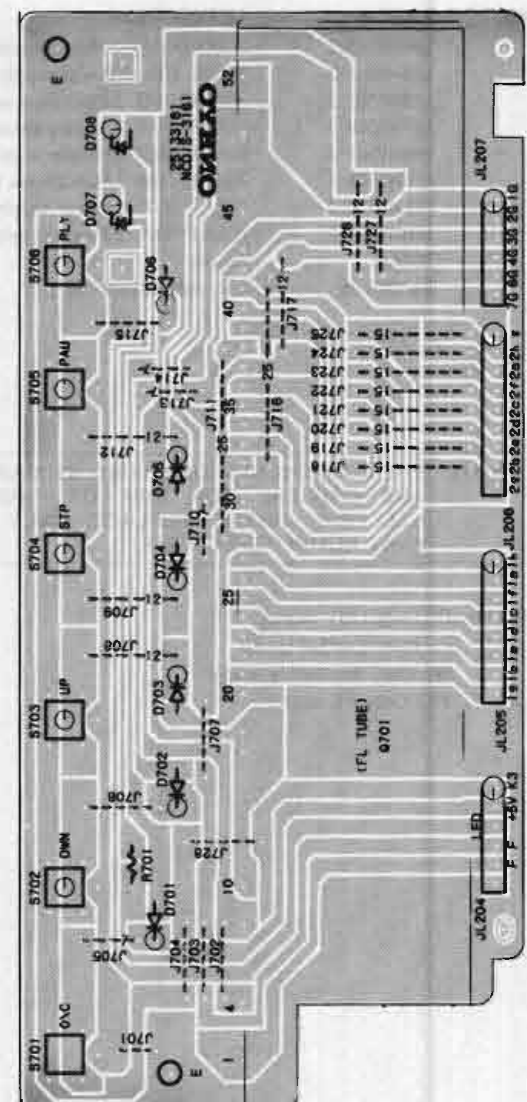

FL TUBE CIRCUIT PC BOARD

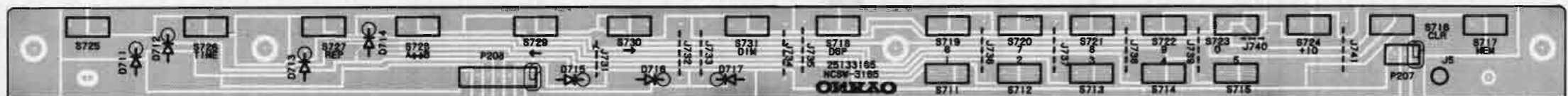

OPERATION SWITCH PC BOARD

# PRINTED CIRCUIT BOARD – PARTS LIST

## DIGITAL CIRCUIT PC BOARD (NADG-3160-3A)

CIRCUIT NO.	PART NO.	DESCRIPTION
		ICs
Q201	22240030	CXA1082AQ
Q202	22240036	STA341M
Q203, Q206	22240033	LA6500
Q207	22240110	CXP5016H-229S
Q208	22240018	M51943ASL
Q212	222963	LB1630
Q213	22240129	CXD1125QZ
Q214	22240118	LC3517AS-15
Q215	221282	DTC144ES
Q301	222755	74HCU04P
Q302	22240176	YM3414
Q303	222740025	74HC02P
Q304	222740745	74HC74P
Q305	222740865	74HC86P
Q911	222780052	78M05
Q912	222790053	79L05
Q913	222780123	78L12
		Transistors
Q209	2212600	DTA124ES
Q210	2211454 or 2211455	2SA1015-Y or 2SA1015-GR
Q211	2211254 or 2211255	2SC1815-Y or 2SC1815-GR
Q306, Q308	2211455	2SA1015-GR
Q307	2211255	2SC1815-GR
Q309-Q312	2211255	2SC1815-GR
Q914	2211643 or 2211644	2SA965-O or 2SA965-Y
		Diodes
D201-D208	223163	1SS133
D209, D211	223150 or 223145	US1040 or 1S2076
D210	223163	1SS133
D911	22380018	DB103
D912-D914	223880 or 223896	GP101N4003 or 1N4003
D915	224652702	HZ27E-B2
D916, D918	224650511	HZ5.1E-B1
D917	223163	1SS133
		Photo couplers
D301-D305	24120013	FCPA00002AT
		X'tal
X301	3010112	KD6586FFB
		Capacitors
C207, C219	354780479	4.7 μF, 50V, Elect.
C221	354742209	22 μF, 16V, Elect.
C223, C224	354784799	0.47 μF, 50V, Elect.
C228, C229	354742209	22 μF, 16V, Elect.
C232, C233	354744709	47 μF, 16V, Elect.
C236	354742209	22 μF, 16V, Elect.
C237	354762209	22 μF, 35V, Elect.
C240, C248	354744709	47 μF, 16V, Elect.
C244	354742209	22 μF, 16V, Elect.
C246	354741009	10 μF, 16V, Elect.
C308	354781099	0.1 μF, 50V, Elect.
C317	354744709	47 μF, 16V, Elect.
C915, C916	354744709	47 μF, 16V, Elect.
C917, C918	354754719	470 μF, 25V, Elect.
C919, C923	354742209	22 μF, 16V, Elect.
C920	354761019	100 μF, 35V, Elect.
C921, C922	354761009	10 μF, 35V, Elect.
C924	354744709	47 μF, 16V, Elect.

CIRCUIT NO.	PART NO.	DESCRIPTION
		Resistors
R203, R204	5210066	N06HR22KBD, Semi-fixed
R228	5210060	N06HR2.2KBD, Semi-fixed
R254-R261	49163472408	4.7K × 8, 1/8W, Network
R317, R322	5210135	N06HR2.2KBE, Semi-fixed
R327	5210135	N06HR2.2KBE, Semi-fixed
R911, R912	442521004	10ohm, 1/2W, Metal oxide film
R917	441520474	4.7ohm, 1/2W, Metal oxide film
		Plugs
P101	25055149	NPLG-5P133
P102	25055151	NPLG-7P135
P103	25055152	NPLG-8P136
P151, P201	25055045	NPLG-4P33
P651	25055137	NPLG-7P21
		Sockets
JL203, JL204	25050269	NSCT-5P97
JL205	25050272	NSCT-8P100
JL206	25050273	NSCT-9P101
JL207	25050270	NSCT-6P98
SC208b	2000791A	NSAS-7P747
SC209b	2000790A	NSAS-3P746
JL210	25050267	NSCT-3P95
JL211	25050270	NSCT-6P98
		Radiator
	27160029-1	RAD-07B
		Screw
	82143006	3P+6FN(BC), Pan head screw
		Bracket
	27141059	Ground
		Fuses
QF901, QF902	252112	ICPN15, IC protector <G>

NOTE: <G>: Only 220V model

## OPERATION SWITCH PC BOARD (NASW-3165-2)

CIRCUIT NO.	PART NO.	DESCRIPTION
D711-D717	223163	1SS133, Diodes
S711-S731	25035570	NPS-111-S532, Push switches
SC209a	2000770A	NSAS-3P726, Socket
SC208a	2000771A	NSAS-7P727, Socket

## FL TUBE CIRCUIT PC BOARD (NADIS-3161-2)

CIRCUIT NO.	PART NO.	DESCRIPTION
		Fluorescent tube
Q701	212051	FIP13JM7
		Diodes
D701-D706	223163	1SS133
		L.E.Ds
D707, D708	225141	SEL2213C
		Switches
S701-S706	25035548	NPS-111-S510
		Holder
	27190454A	L.E.D
		Cushion
	28140780	

# PRINTED CIRCUIT BOARD VIEW FROM BOTTOM SIDE

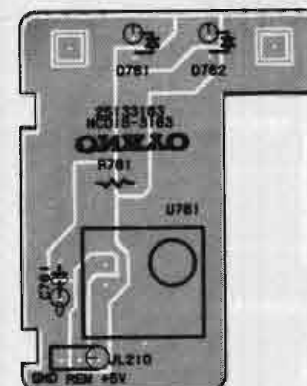

REMOTE CONTROL CIRCUIT PC BOARD

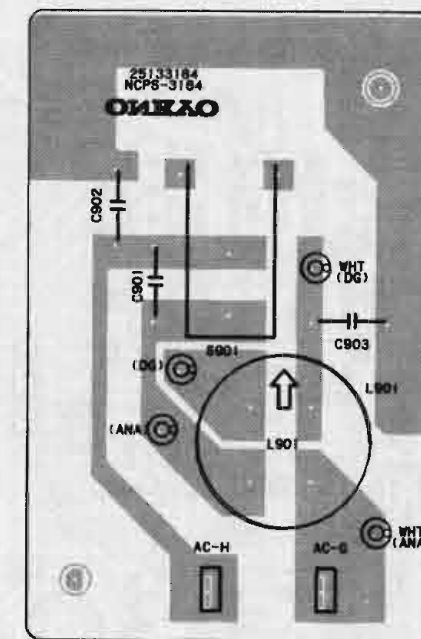

POWER SUPPLY CIRCUIT PC BOARD

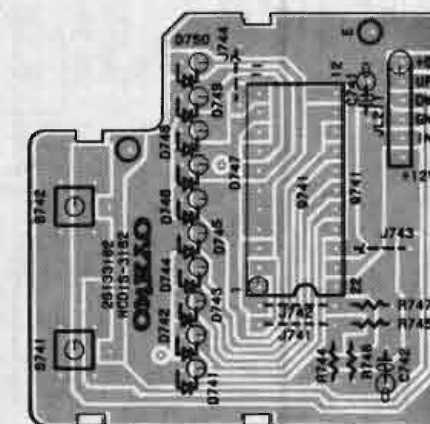

LEVEL INDICATOR CIRCUIT PC BOARD

## REMOTE CONTROL CIRCUIT PC BOARD (NADIS-3163-2)

CIRCUIT NO.	PART NO.	DESCRIPTION
U701	241068	BX1407, IC
D761, D762	225142	SEL2913K, L.E.Ds
C761	355742209	22 μF, 16V, Elect. capacitor
	27190454A	Holder, L.E.D

## POWER SUPPLY CIRCUIT PC BOARD (NAPS-3164-2)

CIRCUIT NO.	PART NO.	DESCRIPTION
C901	3500065A	△ DE7150F103PCSA, Capacitor IS
L901	231051	△ NCH-1092, Line filter
S901	25035550	△ NPS-111-L512P, Power switch
	27300601	△ Cover for C901
	25060092	△ Terminal

## LEVEL INDICATOR CIRCUIT PC BOARD (NADIS-3230-2)

CIRCUIT NO.	PART NO.	DESCRIPTION
		IC
Q741	22240122	IR2406G
		L.E.Ds
D741-D750	225141	SEL2213C
		Capacitor
C742	354742209	22 μF, 16V, Elect.
		Switch
S741, S742	25035548	NPS-111-S510, Push
		Holder
	27190579	L.E.D

NOTE: THE COMPONENTS IDENTIFIED BY MARK △ ARE CRITICAL FOR RISK OF FIRE AND ELECTRIC SHOCK. REPLACE ONLY WITH PART NUMBER SPECIFIED.

PRINTED CIRCUIT BOARD VIEW FROM BOTTOM SIDE

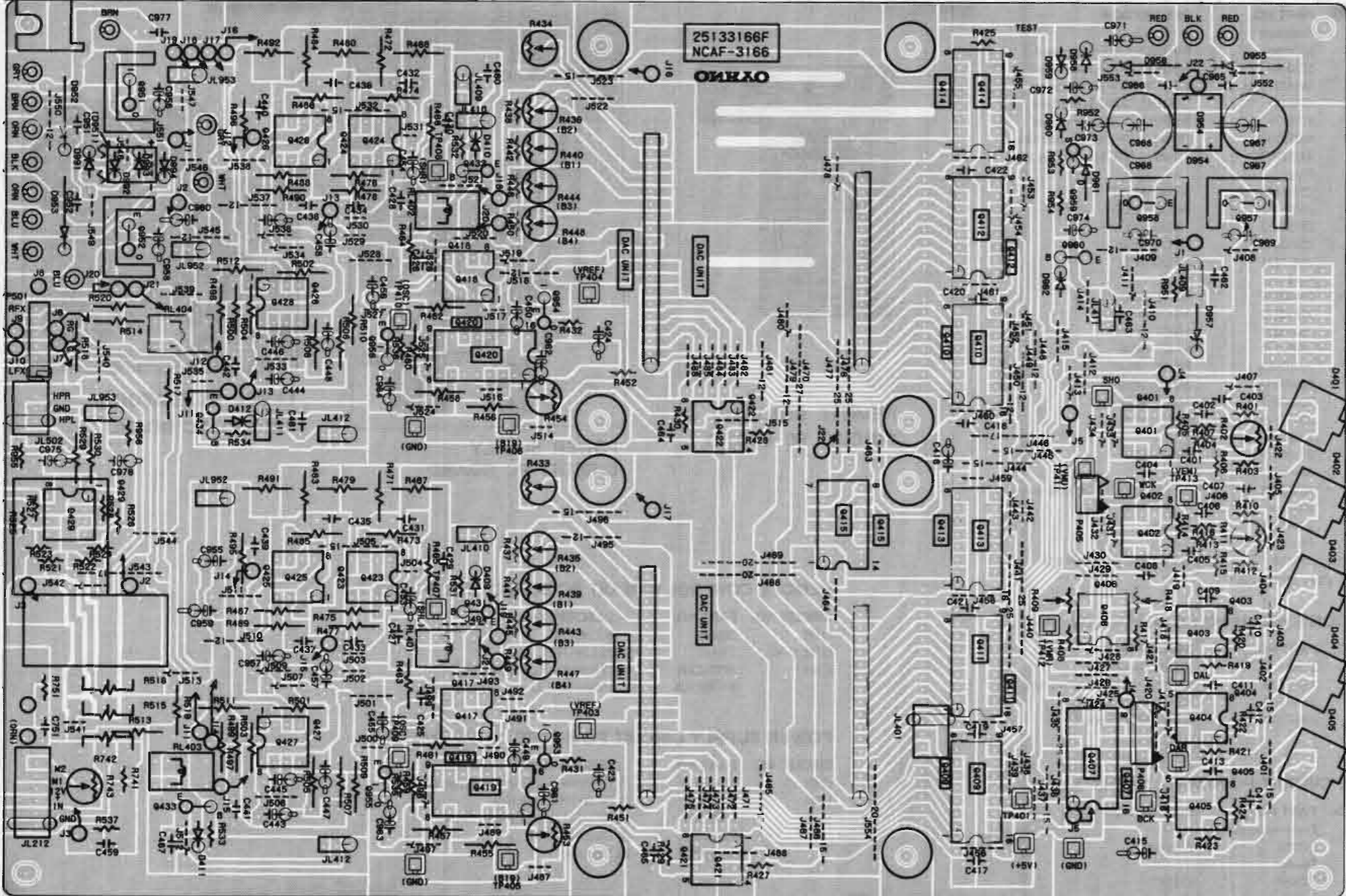

ANALOG CIRCUIT PC BOARD

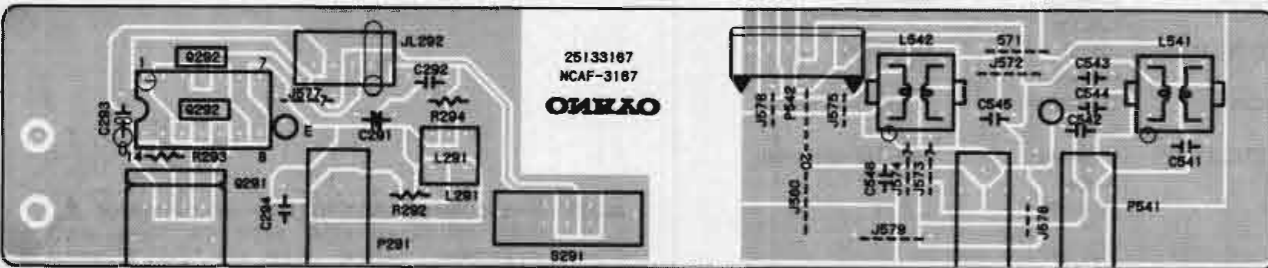

OUTPUT TEMINAL PC BOARD

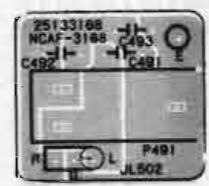

HEADPHONE TERMINAL PC BOARD

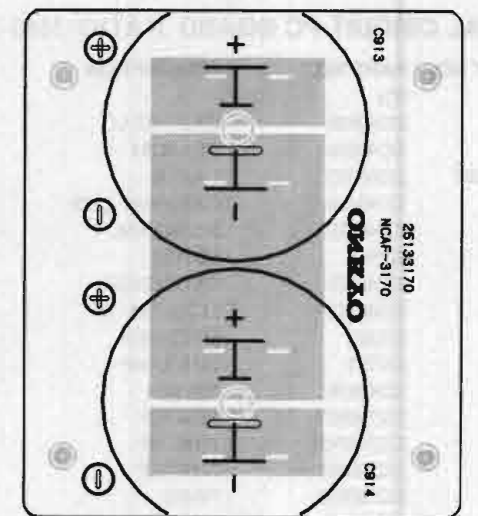

POWER SUPPLY CIRCUIT PC BOARD

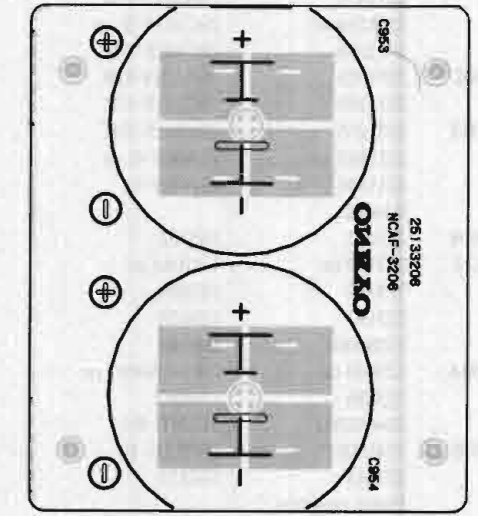

POWER SUPPLY CIRCUIT PC BOARD

# PRINTED CIRCUIT BOARD – PARTS LIST

## ANALOG CIRCUIT PC BOARD(NAAF-3166-3)

CIRCUIT NO.	PART NO.	DESCRIPTION
	DAC ass'y	
	1H046700	NAHC-3169
	ICs	
Q402-Q405	22240035	NJM592D8
Q406	222465	NJM4558D
Q407	22240119	74HC4050P
Q409-Q414	222745955	74HC595P
Q415	222755	74HCU04P
Q417,Q418	22240120	# PC813C
Q419,Q420	222717	# PD4053BC
Q421,Q422	226027	HCPL-2601
Q425-Q428	222902	NJM5532D-D
Q429	222654	NJM4556D
Q951	222780155MIT	M5F78M15L
Q952	222790155MIT	M5F79M15L
Q953,Q954	222780053	78L05
Q955,Q956	222790053	79L05
Q957	222780055MIT	M5F78M05L
Q958	222790055MIT	M5F79M05L
	Transistors	
Q431-Q434	2211255	2SC1815-GR
Q959	2211945	2SK246-GR
Q960	221282	DTC144ES
	Photo couplers	
D401-D405	2410571	FCPA00001ARA
	Diodes	
D409-D412	223163	1SS133
D951,D954	22380013	RDF02M
D957	224650511	HZ5.1EB1
D958-D960	223163	1SS133
D961	22460822 or 2243192	HZ8.2EB2 or MTZ8.2B
D962	223163	1SS133
	Capacitors	
C415,C416	354744709	47 $\mu$ F,16V,Elect.
C425,C426	372123314	330pF $\pm$ 5%,50V,Styrole
C427,C428	372123324	3300pF $\pm$ 5%,50V,Styrole
C429,C430	372122224	2200pF $\pm$ 5%,50V,Styrole
C435-C440	372122224	2200pF $\pm$ 5%,50V,Styrole
C441,C442	372123314	330pF $\pm$ 5%,50V,Styrole
C443-C450	391242207	22 $\mu$ F,16V,Elect.
C453-C456	391262217	220 $\mu$ F,35V,Elect.
C951,C952	379121045	0.1 $\mu$ F $\pm$ 10%,50V,Plastic
C955,C957	391242207	22 $\mu$ F,16V,Elect.
C956,C958	391262217	220 $\mu$ F,35V,Elect.
C961-C964	391242207	220 $\mu$ F,16V,Elect.
C967	354743329	3300 $\mu$ F,16V,Elect.
C968	354742229	2200 $\mu$ F,16V,Elect.
C969,C970	354742209	22 $\mu$ F,16V,Elect.
C971,C972	354780479	4.7 $\mu$ F,50V,Elect.
C973	354784799	0.47 $\mu$ F,50V,Elect.
C974	354742209	22 $\mu$ F,16V,Elect.
C976	354742219	220 $\mu$ F,16V,Elect.
C978	375104745	0.47 $\mu$ F $\pm$ 10%,125V,Plastic
C979	379121525	1500pF $\pm$ 10%,50V,Plastic
	Resistors	
R409,R418	5210062	N06HR4.7KBD,Semi-fixed
R411	5210066	N06HR22KBD,Semi-fixed
R433,R434	5210064	N06HR10KBD,Semi-fixed
R435,R436	5210070	N06HR100KBD,Semi-fixed
R439,R440	5210070	N06HR100KBD,Semi-fixed
R443,R444	5210070	N06HR100KBD,Semi-fixed
R447,R448	5210070	N06HR100KBD,Semi-fixed

CIRCUIT NO.	PART NO.	DESCRIPTION
R515,R516	5104218	N16RTL20KA10M,Variable resistor
	Relaies	
RL401-RL404	25065327	NRL-1P0.5A-DC05-044
	Sockets	
JL401	25050267	NSCT-3P95
SC501	2000772A	NSAS-6P728
JL502	25050267	NSCT-3P95
JL212	25050269	NSCT-5P97
	Radiators	
	27160145	RAD-51
	Screws	
	82143006	3P+6FN(BC),Pan head

## OUTPUT TERMINAL PC BOARD(NAAF-3167-2)

CIRCUIT NO.	PART NO.	DESCRIPTION
Q291	24120019	TOTX-175,Opto. module
Q292	222755	74HCU04P,IC
L291	232143	NSRF-2047,RF coil
C291	352942206	22 $\mu$ F,16V,Non-polar elect.capacitor
C293	354744709	47 $\mu$ F,16V,Elect.capacitor
C541,C542	372522214	220pF $\pm$ 5%,50V,Styrole capacitors
C545,C546	372521514	150pF $\pm$ 5%,50V,Styrole capacitors
P291	25045220	NPJ-1PDOR97,Digital output terminal
P541	25045236	NPJ-4PDBL110,Audio output terminal
JL292	25050268	NSCT-4P96,Socket
P542	25055037	NPLG-6P28,Plug
S291	25065286	NSS-22112,Slide switch

## HEADPHONE TERMINAL PC BOARD(NAAF-3168-1)

CIRCUIT NO.	PART NO.	DESCRIPTION
P491	25045221	HLJ0540-01-410,Stereo headphone terminal

## POWER SUPPLY CIRCUIT PC BOARDS(NAAF-3170-2/3206-2)

CIRCUIT NO.	PART NO.	DESCRIPTION
C913,C914	3500102	10,000 $\mu$ F,50V,Elect.capacitors
C953,C954	3500102	10,000 $\mu$ F,50V,Elect.capacitors

# SCHEMATIC DIAGRAM

## LOADING MOTOR BOARD

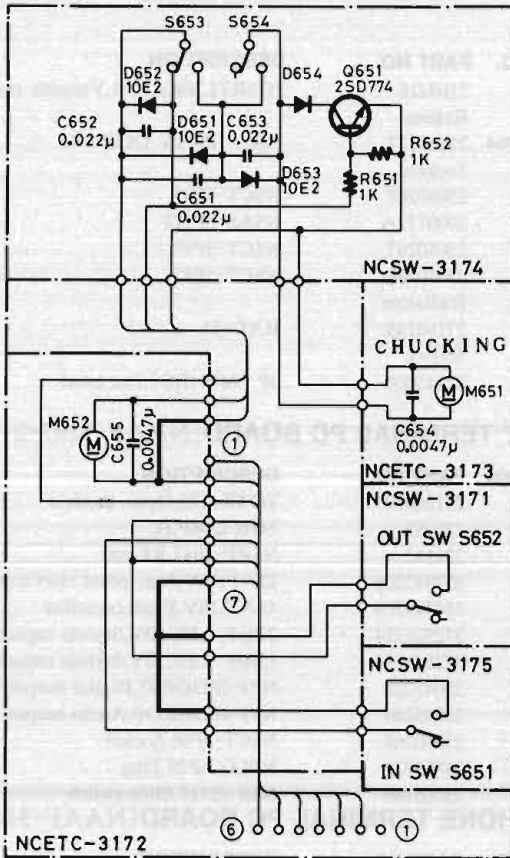

## BSL MOTOR BOARD

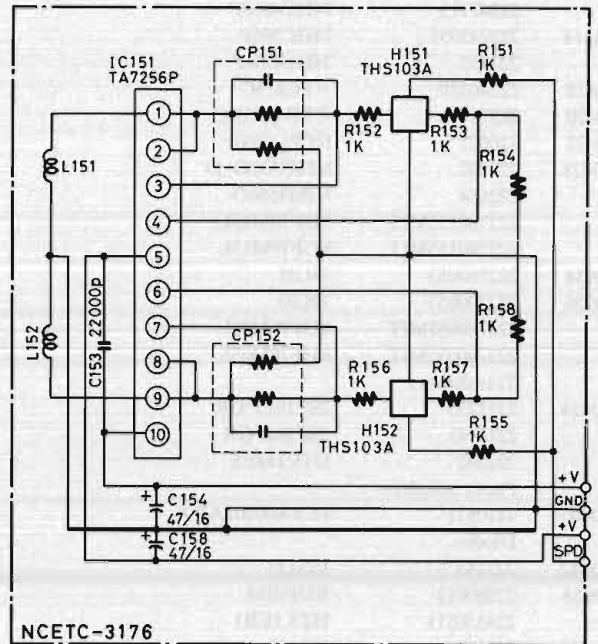

## RF BOARD

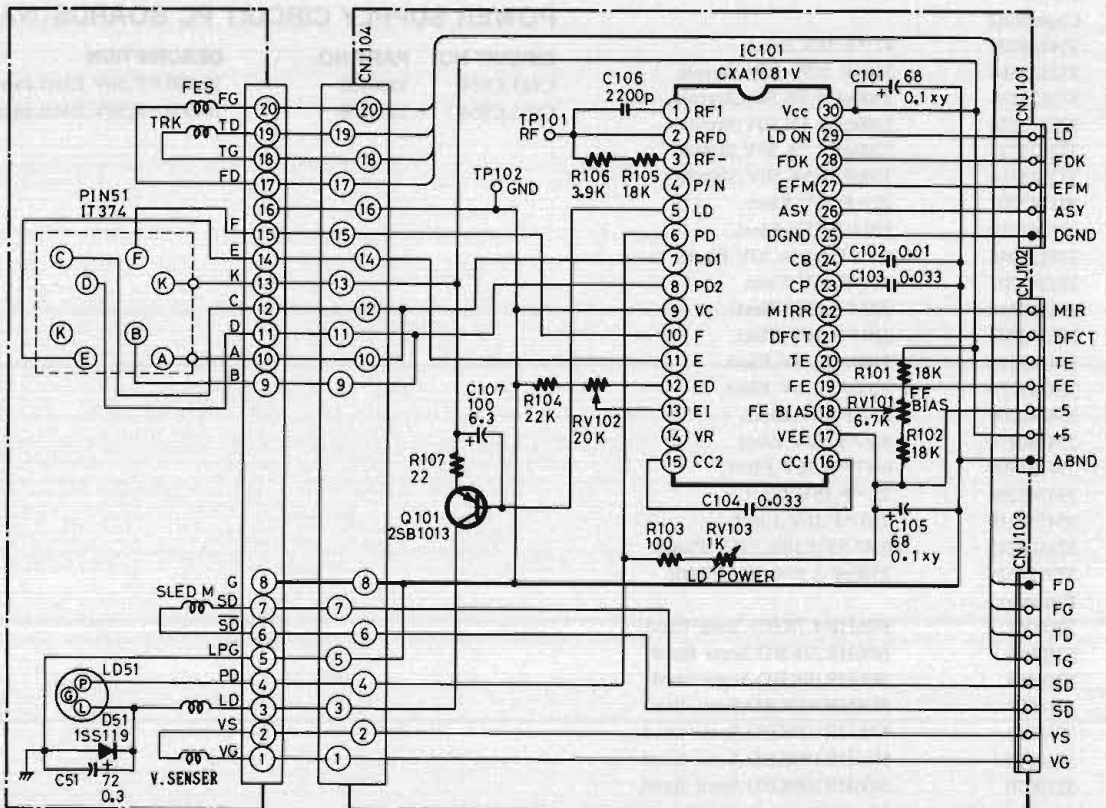

# SCHEMATIC DIAGRAM

SCHEMATIC DIAGRAM

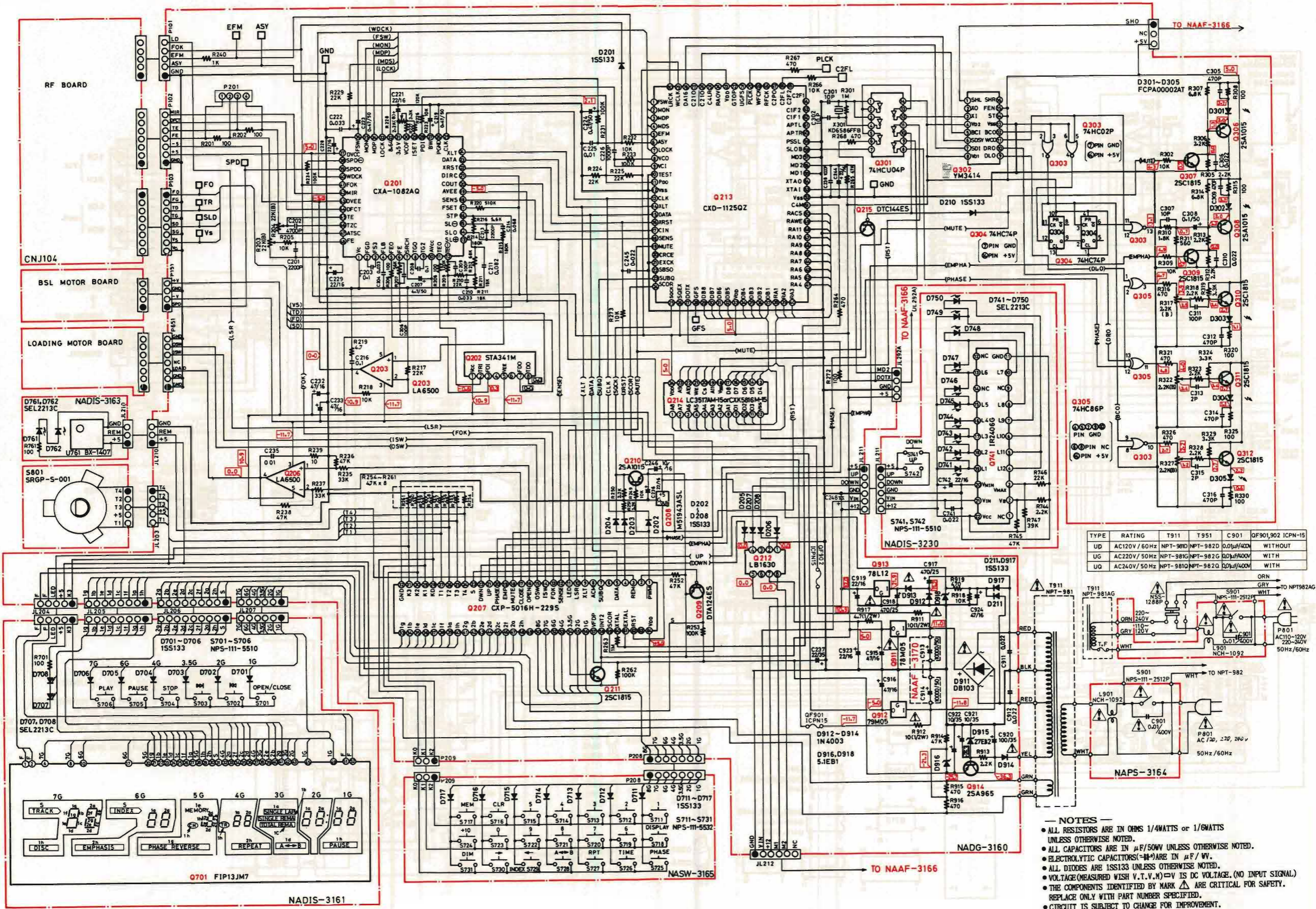

TYPE	RATING	T911	T951	C901	QF901,902	ICPN-15
UD	AC120V / 60Hz	NPT-981D	NPT-982D	0.01μF/400V	WITHOUT	
UG	AC220V / 50Hz	NPT-981G	NPT-982G	0.01μF/400V	WITH	
UG	AC240V / 50Hz	NPT-981G	NPT-982G	0.01μF/400V	WITH	

- NOTES —
- ALL RESISTORS ARE IN OHMS 1/4WATTS or 1/6WATTS UNLESS OTHERWISE NOTED.
  - ALL CAPACITORS ARE IN μF/50WV UNLESS OTHERWISE NOTED.
  - ELECTROLYTIC CAPACITORS (E) ARE IN μF / V.
  - ALL DIODES ARE 1SS133 UNLESS OTHERWISE NOTED.
  - VOLTAGE (MEASURED WITH V.T.V.M) IS DC VOLTAGE. (NO INPUT SIGNAL).
  - THE COMPONENTS IDENTIFIED BY MARK Δ ARE CRITICAL FOR SAFETY. REPLACE ONLY WITH PART NUMBER SPECIFIED.
  - CIRCUIT IS SUBJECT TO CHANGE FOR IMPROVEMENT.

# SCHEMATIC DIAGRAM

SCHEMATIC DIAGRAM

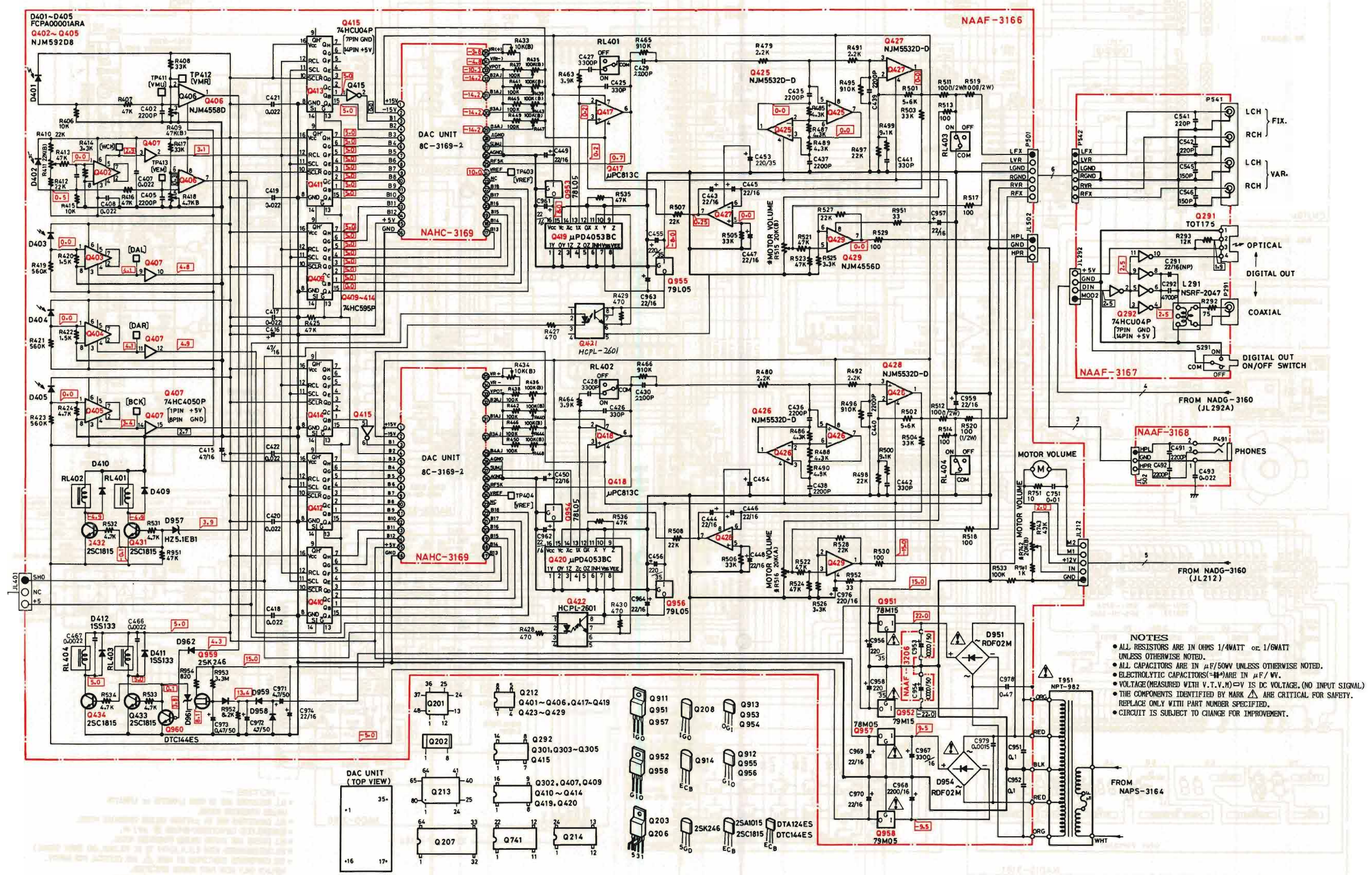

**NOTES**

- ALL RESISTORS ARE IN OHMS 1/4WATT OR 1/6WATT UNLESS OTHERWISE NOTED.
- ALL CAPACITORS ARE IN  $\mu\text{F}/50\text{V}$  UNLESS OTHERWISE NOTED.
- ELECTROLYTIC CAPACITORS (E) ARE IN  $\mu\text{F}/\text{V}$ .
- VOLTAGE (MEASURED WITH V.T.V.M)  $\Rightarrow$  IS DC VOLTAGE. (NO INPUT SIGNAL).
- THE COMPONENTS IDENTIFIED BY MARK  $\Delta$  ARE CRITICAL FOR SAFETY. REPLACE ONLY WITH PART NUMBER SPECIFIED.
- CIRCUIT IS SUBJECT TO CHANGE FOR IMPROVEMENT.



# WAVEFORM OF EACH SECTION

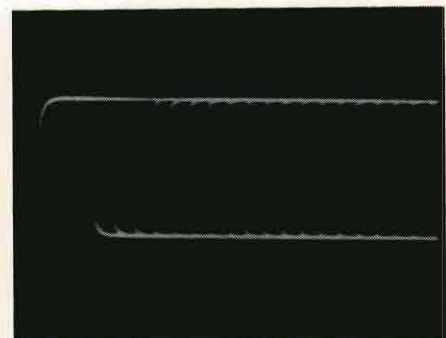

**Photo 1**  
EFM signal  
Vertical:1V/div.  
Horizontal:5  $\mu$ s/div.  
Insert the resistor 2.2kohm between probe of oscilloscope and test point.



**Photo 2**  
Focus signal  
Upper P201  
Lower FO(T.P)  
Vertical:0.2V/div.  
Horizontal:5ms/div.

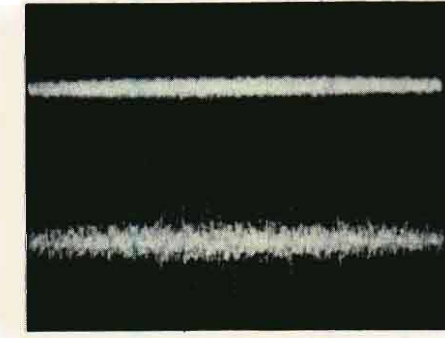

**Photo 3**  
Tracking signal  
Upper P201  
Lower TR(T.P)  
Vertical:1V/div.  
Horizontal:5ms/div.

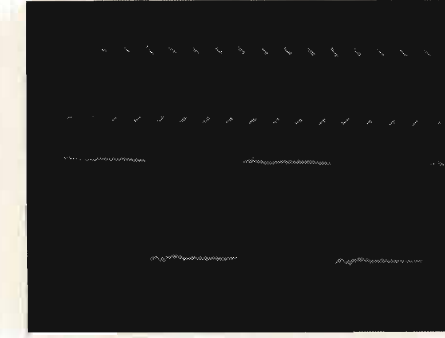

**Photo 4**  
Upper OSC output Pin 3 of Q302  
Lower BCLK signal Pin 5 of Q302  
Vertical:2V/div.  
Horizontal:0.1  $\mu$ s/div.

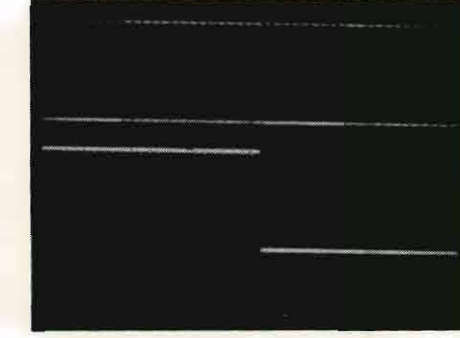

**Photo 5**  
Upper DATA signal Pin 7 of Q302  
Lower LRCK signal Pin 5 of Q302  
Vertical:2V/div.  
Horizontal:5  $\mu$ s/div.

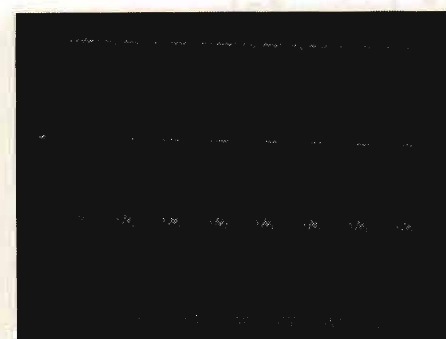

**Photo 6**  
Upper DLO signal Pin 3 of Q305  
Lower DCO signal Pin 10 of Q303  
Vertical:2V/div.  
Horizontal:0.1  $\mu$ s/div.

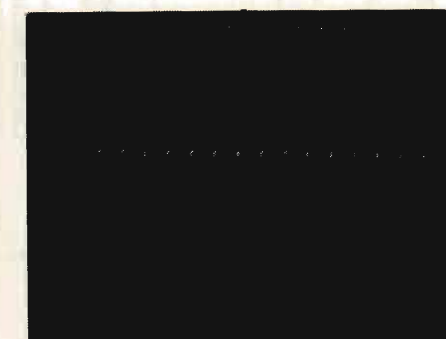

**Photo 7**  
X'tal osc. output Pin 1 of Q301  
Vertical:1V/div.  
Horizontal:0.1  $\mu$ s/div.

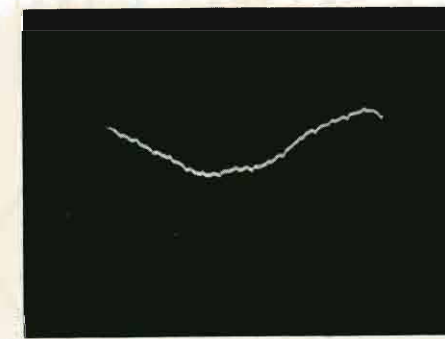

**Photo 8**  
SLD signal(T.P) When play  
Vertical:1V/div.  
Horizontal:20ms/div.

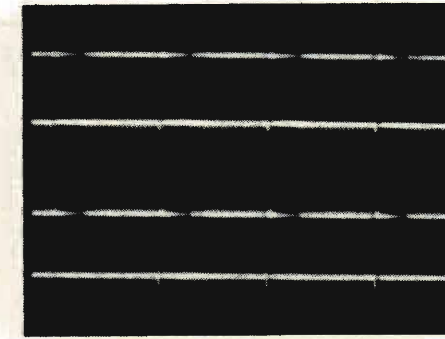

**Photo 9**  
Upper DAL signal(T.P)  
Lower DAR signal(T.P)  
Vertical:2V/div.  
Horizontal:2  $\mu$ s/div.

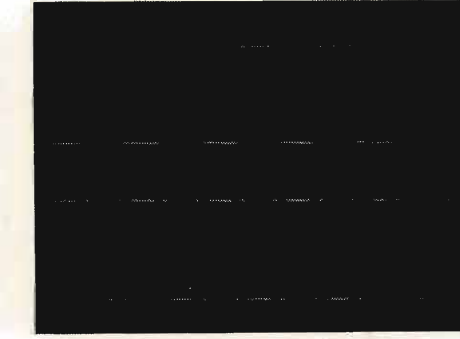

**Photo 10**  
Serial/Parallel change  
Pins 1 & 15 of Q413  
Vertical:2V/div.  
Horizontal:0.5ms/div.

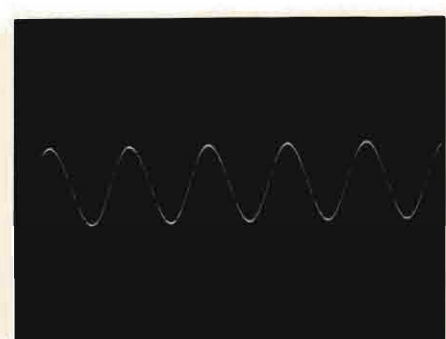

**Photo 11**  
Audio output  
Pins 6 of Q417 & Q418  
Vertical:5V/div.  
Horizontal:0.5ms/div.

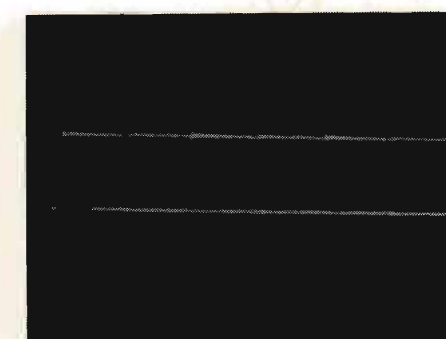

**Photo 12**  
Digital output  
Vertical:20mV/div.  
Horizontal:0.2  $\mu$ s/div.

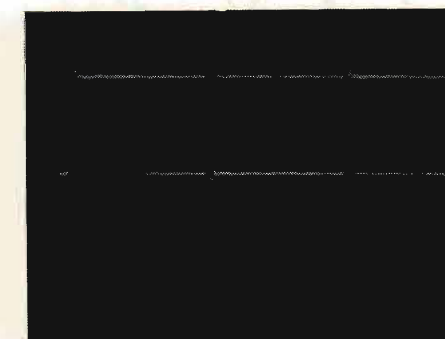

**Photo 13**  
Digital opto. output  
Vertical:2V/div.  
Horizontal:0.1  $\mu$ s/div.

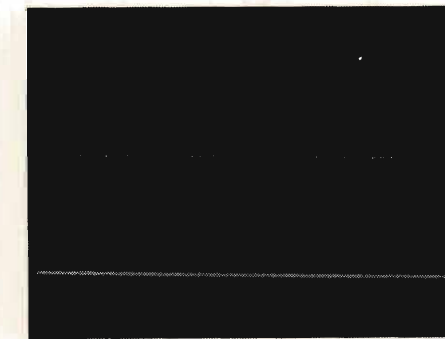

**Photo 14**  
Grid signal of FL tube(Pin 50 of Q207)  
Vertical:10mV/div.  
Horizontal:1ms/div.

**NOTE:**Play the track 2 of test disc.(YEDS-18)

TROUBLESHOOTING GUIDE

# TROUBLESHOOTING GUIDE

Load the disc on the tray, press OPEN/CLOSE key and close the tray. But, the total time and total number of tunes are not indicated on the fluorescent indicator tube.

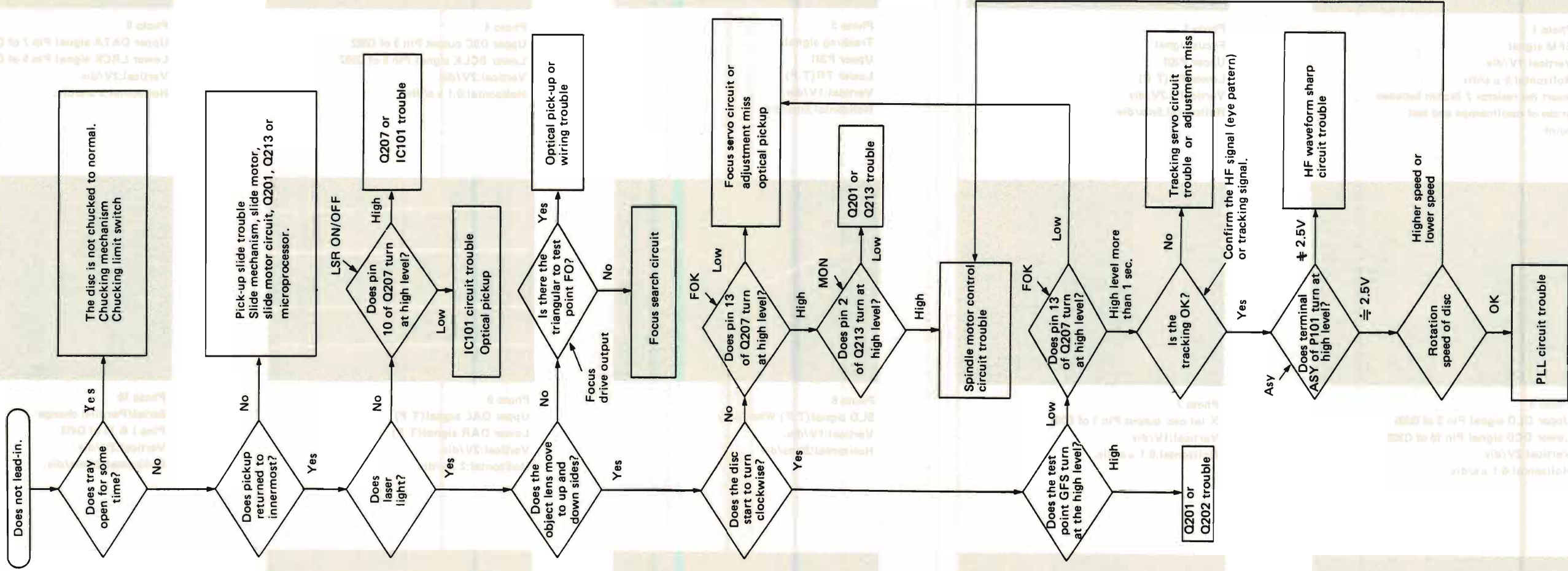

BLOCK DIAGRAM

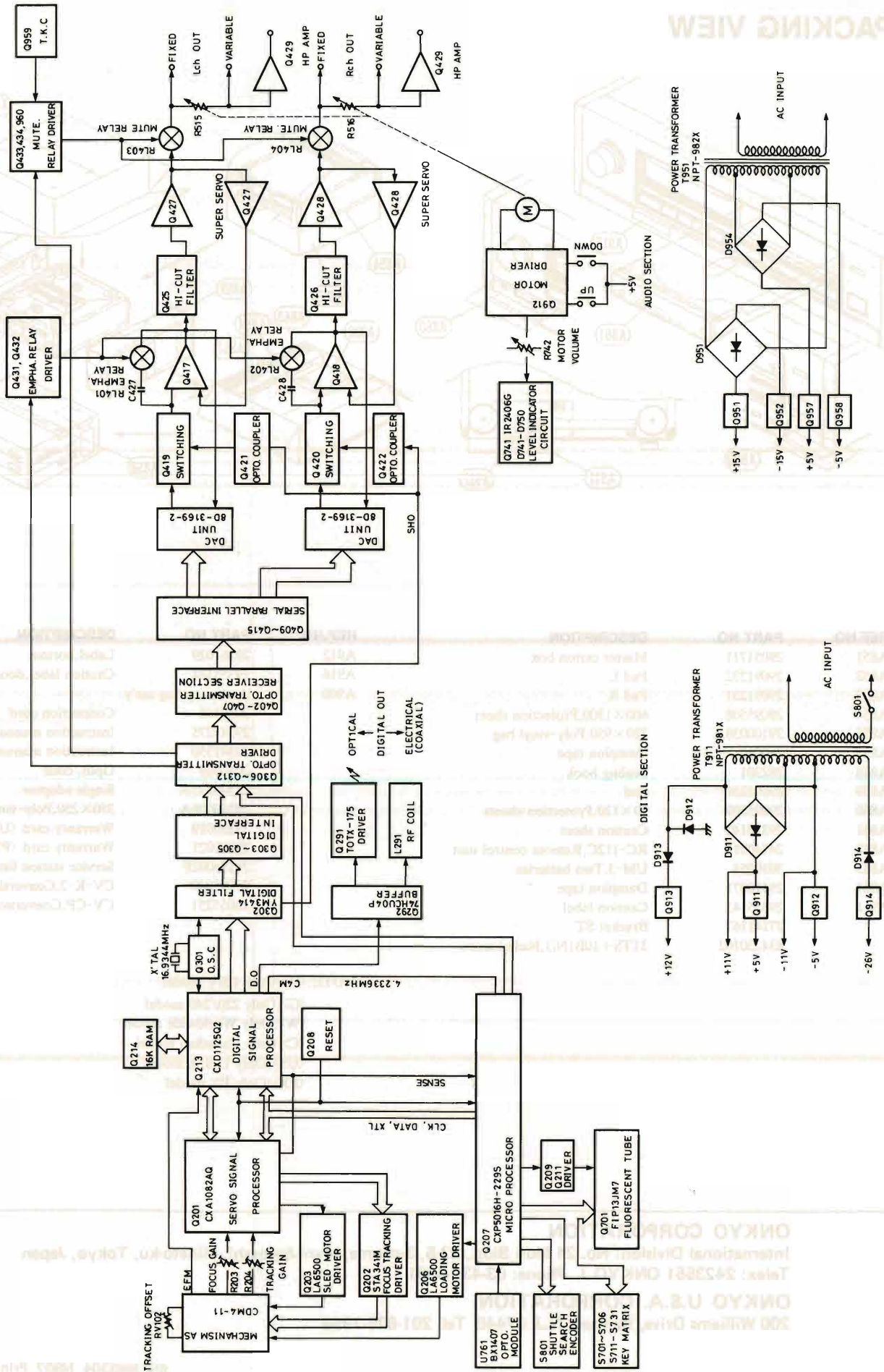

# PACKING VIEW

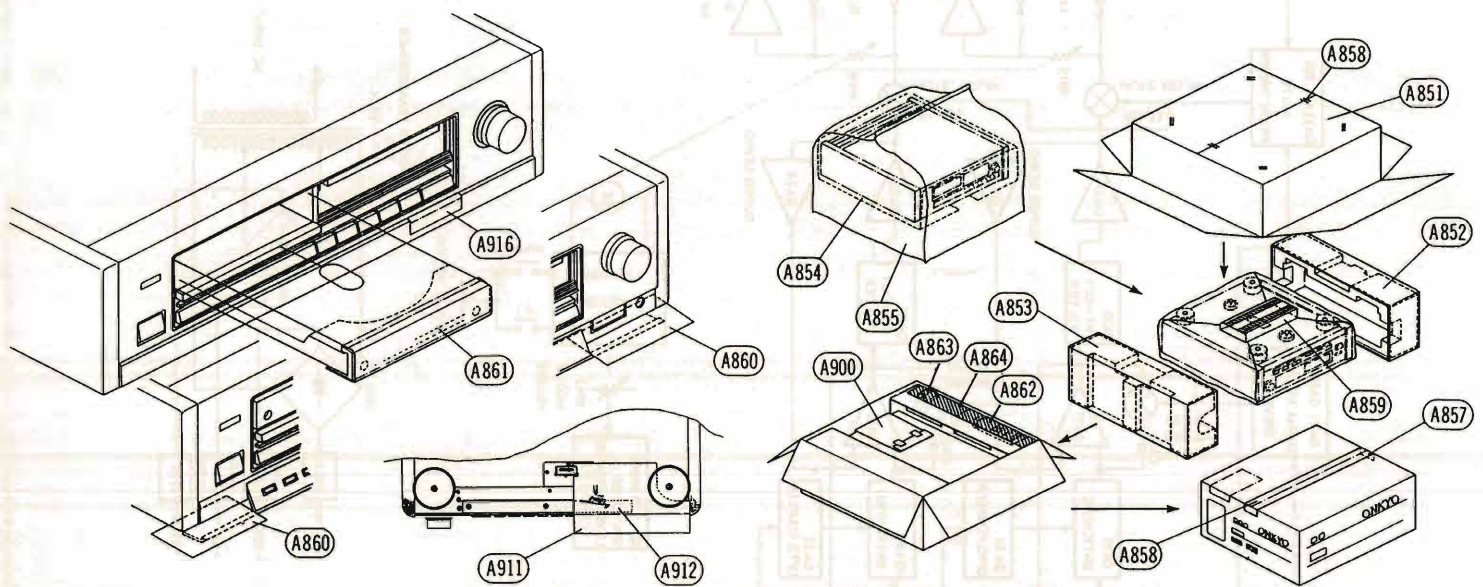

REF.NO.	PART NO.	DESCRIPTION
A851	29051711	Master carton box
A852	29091232	Pad L
A853	29091231	Pad R
A854	29095508	600×1300,Protection sheet
A855	29100038A	720×950,Poly-vinyl bag
A857	260012	Damplon tape
A858	282301	Sealing hook
A859	29091230	Pad
A860	29095509	70×120,Protection sheets
A861	29355142	Caution sheet
A862	24140015	RC-112C,Remote control unit
A863	3010054	UM-3,Two batteries
A864	29110071	Damplon tape
A911	29355143	Caution label
	27141167	Bracket ST
	834230102	3TTS+10B(Ni),Nickel screw

REF.NO.	PART NO.	DESCRIPTION
A912	29361029	Label,bottom
A916	29355144	Caution label,door
A900	Accessory bag ass'y	
	2010166	Connection cord
	29341275	Instruction manual <D/PX>
	29341350	Instruction manual <C/G/W>
	2050005	Opto. code
	24509395A	Single adaptor
	29100006A	350×250,Poly-vinyl bag
	29365019	Warranty card <US>
	29365021	Warranty card <PX>
	29358002F	Service station list <US/PX>
	25055040	CV-K-2,Conversion plug <W>
	25055251	CV-CP,Conversion plug <PX>

NOTE: <D>:Only 120V model  
 <G>:Only 220/240 model  
 <W>:Only Worldwide model  
 <C>:Only Canadian model  
 <US>:Only U.S.A model  
 <PX>:Only PX model

## ONKYO CORPORATION

International Division: No. 24 Mori Bldg., 23-5, 3-chome, Nishi-Sinbashi, Minato-ku, Tokyo, Japan  
 Telex: 2423551 ONKYO J. Phone: 03-432-6981

## ONKYO U.S.A. CORPORATION

200 Williams Drive, Ramsey, N.J. 07446 Tel. 201-825-7950